

Spreaders for Snow & Ice Control

FOR MODELS

Bulk-Pro 1875

Pivot-Pro 1075

Mini-Pro 575

Junior 325

INTRODUCTION.....	3
GENERAL INFORMATION AND REGISTRATION	4
SAFETY PRECAUTIONS	5-6
• PREPARATION	
• OPERATIONS	
• SERVICE	
SPREADER PARTS/DIAGRAMS.....	7-13
• BULK PRO 1875	
• PIVOT PRO 1075	
• MINI PRO 575	
• DRIVE MOTOR ENCLOSURE ASSEMBLY	
• JUNIOR 325	
WIRING INSTRUCTIONS.....	14-20
BLANK PAGE	21
OPERATING THE SPREADER	22-23
ADJUSTABLE DEFLECTOR.....	24-25
GATE ASSEMBLY.....	26-27
VIBRATOR KIT	28
SPREADER MOUNT PARTS/DIAGRAMS	29-42
• RECEIVER HITCH MOUNT	
• PIVOT MOUNT	
• 3-POINT MOUNT	
• TRAILER MOUNT	
• DROP UTILITY MOUNT	
• UTILITY MOUNT	
• PIVOT PAL HITCH MOUNT	
TROUBLESHOOTING	43-48
SPREADER MAINTENANCE	49
WARRANTY.....	50-51

Have a question or need assistance?
SnowEx Customer Service
(800) 725-8377

or (586) 756-6555

Monday through Friday 8:00 AM to 4:30 PM EST

Fax: (586) 427-0552

E-Mail: customercare@trynexfactory.com

Website: www.snowexproducts.com

This manual has been designed for your help. It will assist you and instruct you on the proper set-up, installation and use of this spreader.

Refer to the table of contents for an outline of this manual.

We require that you read and understand the contents of this manual completely (especially all safety information) before attempting any procedure contained herein.



THIS SIGN SHOULD ALERT YOU:

The Society of Automotive Engineers has adopted this SAFETY ALERT SYMBOL to pinpoint characteristics that, if NOT carefully followed, can create a safety hazard. When you see this symbol in this manual or on the machine itself, BE ALERT! Your personal safety and the safety of others is involved.

Defined below are the SAFETY ALERT messages and how they will appear in this manual:



DANGER

(RED)

Information that, if not carefully followed, can cause death!



WARNING

(ORANGE)

Information that, if not carefully followed, can cause serious personal injury or death!



CAUTION

(YELLOW)

Information that, if not carefully followed, can cause minor injury or damage to equipment.

CONGRATULATIONS!

The spreader you have purchased is an example of snow and ice control technology at its finest! Your spreader's self-contained design is a trademark of all Snowex products. Here's why...

SIMPLICITY: Fewer moving parts manufactured of higher quality means minimal maintenance for your SnowEx spreader.

RELIABILITY: High impact linear low density polyethylene hopper, state-of-the-art electronic dual variable speed control, custom engineered powder coated frame, maximum torque 12 volt motor coupled to a custom engineered transmission found only on SnowEx products.

VERSATILITY: Multi-use capabilities allows spreading of a variety of materials for snow and ice control.

WARRANTY: Best in the industry, hands down! 2 years standard and now 5 year extended (optional).

The benefits you are about to recognize are that of time, money and effort. We welcome you to the world of Snowex Performance.

Registration

Record the following information in this manual for quick reference.

Spreader Model Number _____

Spreader Serial Number _____ Controller Serial Number _____

Date of Purchase _____

Dealer Where Purchased _____

When ordering parts, the above information is necessary. This will help to insure that you receive the correct parts.

At the right is a diagram of the ID tag. This tag on the spreader is located on the frame.

Please fill out the warranty card with all the necessary information to validate it. This will also give us a record so that any safety or service information can be communicated to you.





Before attempting any procedure in this book, these safety instructions must be read and understood by all workers who have any part in the preparation or use of this equipment.

For your safety, warning and information decals have been placed on this product to remind the operator of safety precautions. If anything happens to mark or destroy the decals, please request new ones from Snowex.



Unit must be pinned and locked into position before operating vehicle.



Never exceed the Gross Vehicle Weight Rating of vehicle. Failure to do so may limit a vehicle's handling characteristics.



Never attempt to take a unit off a truck with material in it.



Never exceed 45 m.p.h. when loaded spreader is attached to vehicle. Braking distances may be increased and handling characteristics may be impaired at speeds above 45 m.p.h.



Never allow children to operate or climb on equipment.
Always check areas to be spread to be sure no hazardous conditions or substances are in the area.
Always inspect unit for defects: broken, worn or bent parts, weakened areas on spreader or mount.



Always shut off vehicle and power source before attempting to attach or detach or service spreader unit. Be sure vehicle/power source is properly braked or chocked.



Always keep hands, feet, and clothing away from power-driven parts. Remember it is the owner's responsibility to communicate information on safe usage and proper maintenance of all equipment.









Always make sure personnel are clear of areas of danger when using equipment. Maintain 60' distance from all bystanders when operating the spreader.



Inspect the unit periodically for defects. Parts that are broken, missing, or worn out must be replaced immediately. The unit, or any part of it can not be altered without prior written permission from the manufacturer.



Never use with foreign debris in the spreader. These units are designed to handle clean, free-flowing material.

-  **WARNING** Always inspect pins and latches whenever attaching or detaching spreader, and before traveling.
-  **CAUTION** Never leave material in hopper for long periods of time. Be aware that all ice melters are hygroscopic and will attract atmospheric moisture and harden up.
-  **WARNING** Remember, most accidents are preventable and caused by human error. Exercising of care and precautions must be observed to prevent the possibility of injury to operator or others!
-  **WARNING** Never operate equipment when under the influence of alcohol, drugs, or medication that might alter your judgment and/or reaction time.
-  **WARNING** Before working with the spreader, secure all loose fitting clothing and unrestrained hair.
-  **WARNING** Always wear safety glasses with side shields when servicing spreader. Failure to do this could result in serious injury to the eyes.

Examples of warning decals to indicate operational awareness.



1 D 6546



2 D 6547



3 D 6545



4 D 6544

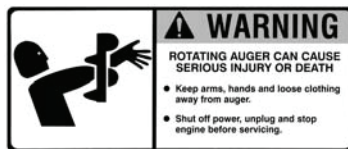

5 D 6335

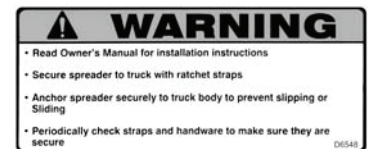

6 D 6548

Parts Breakdown

Model #SP-1875

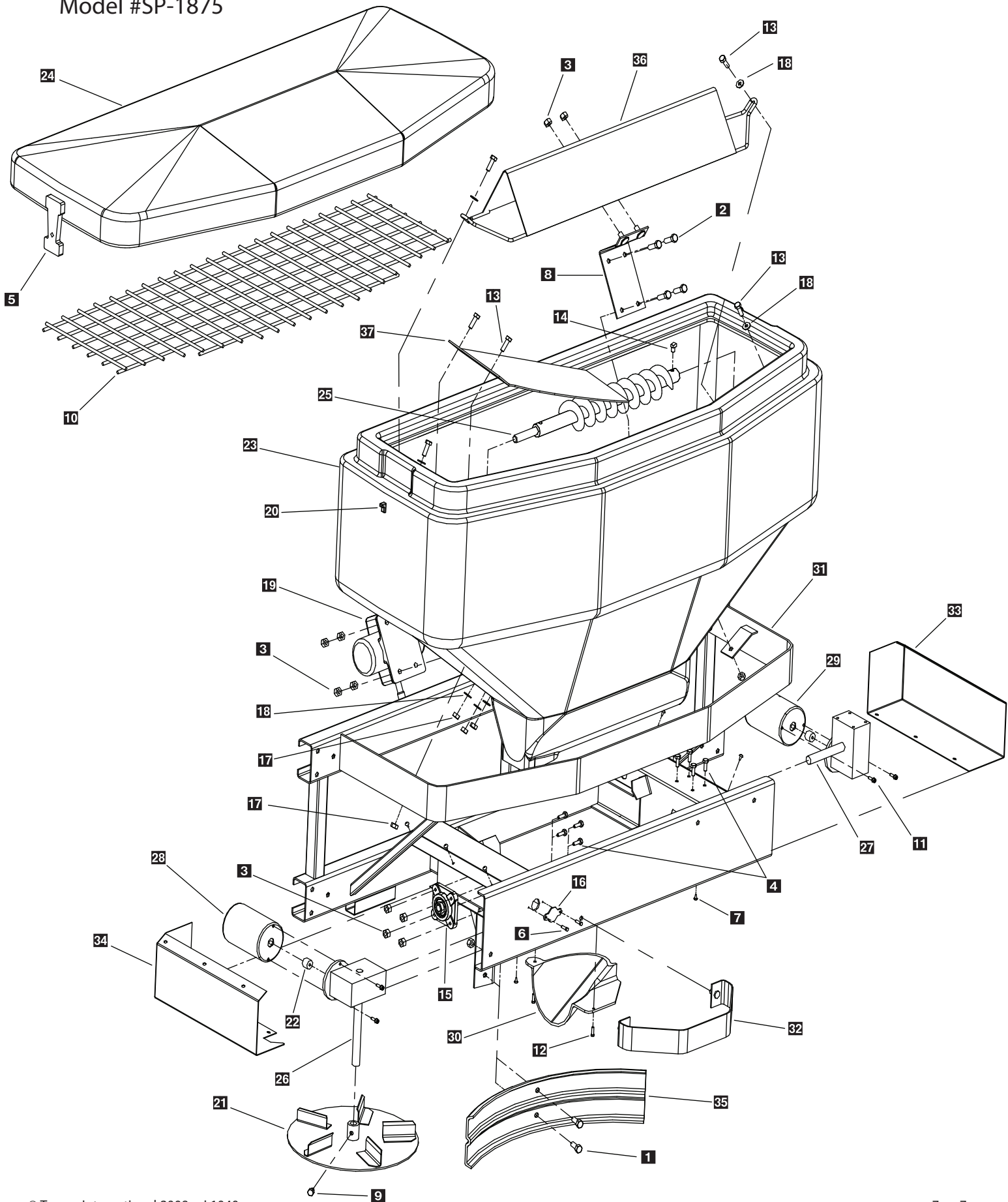

Parts Breakdown

Model #SP-1875

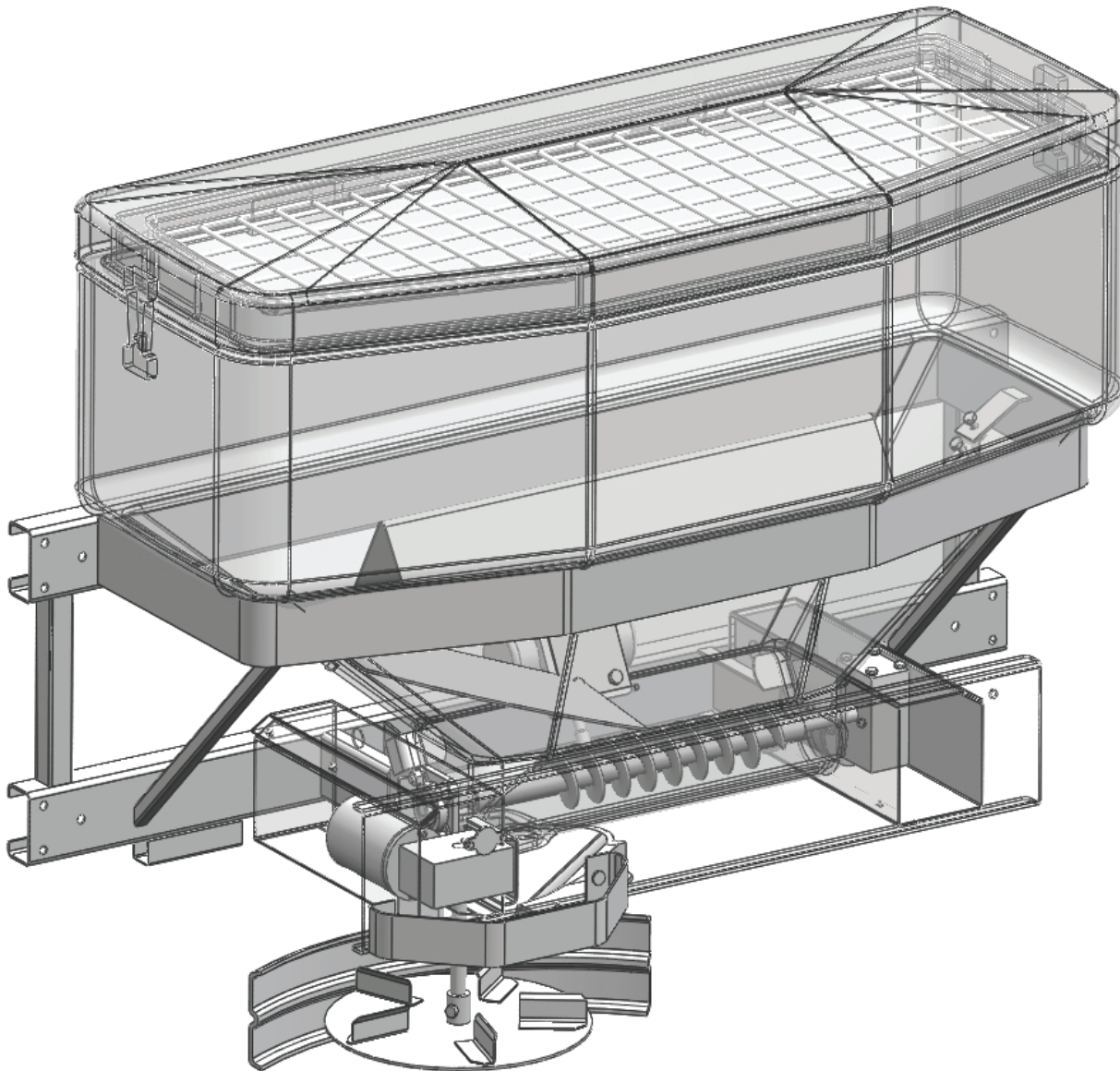

Key	Part No.	Description	Qty.	Key	Part No.	Description	Qty.	Key	Part No.	Description	Qty.
1	D 6452	3/8-16x1" Ser Flg Bolt	2	16	D 6356	Bearing Access Cover	1	31	D 6323	1875 Frame	1
2	D 4122	3/8-16x1-1/2" Hex Bolt	4	17	D 6394	5/16-18 KEPS Nut	8	32	D 6324	Trim Ring	1
3	D 4124	3/8-16 Lock Nut	8	18	D 6169	3/8" SS Flat Washer	10	33	D 6325	Auger Mtr Motor Cover	1
4	D 6132	1/4-20 x 3/4 Ser Flg SS	8	19	D 6174	DC-80 Vibrator	1	34	D 6326	Spinner Mtr Cover	1
5	D 6105	Flexible Draw Latch	2	20	D 6198	Latch Keeper	2	35	D 6327	Plastic Deflector	1
6	D 6877	#8 x 3/4 Driller	2	21	D 6225	12" Steel Spinner	1	36	D 6328	Inverted V-Support	1
7	D 6130	3/16" Aluminum Rivit	12	22	D 6232	Motor Trans Coupler	2	37	D 6330	Material Baffle	1
8	D 6337	Inverted V-Mtg Brkt	1	23	D 6313	1875 Hopper	1				
9	D 6133	5/16-18 x 1/2" Hex Bolt	1	24	D 6314	1875 Lid	1				
10	D 6334	Top Screen	1	25	D 6315	Auger	1				
11	D 6135	10/32 x 5/8" Cap Screw	4	26	D 6317	Spinner Transmission	1				
12	D 6333	3/16" Rivet, Long	2	27	D 6501	Auger Transmission	1				
13	D 6137	5/16-18 x 1" PH SS Bolt	6	28	D 6106	Spinner Motor	1				
14	D 6140	5/16-18 x 3/8" Set Screw	1	29	D 6320	Auger Motor	1				
15	D 6332	Auger Shaft Bearing	1	30	D 6331	Chute	1				

Parts Breakdown

Model #SP-1075

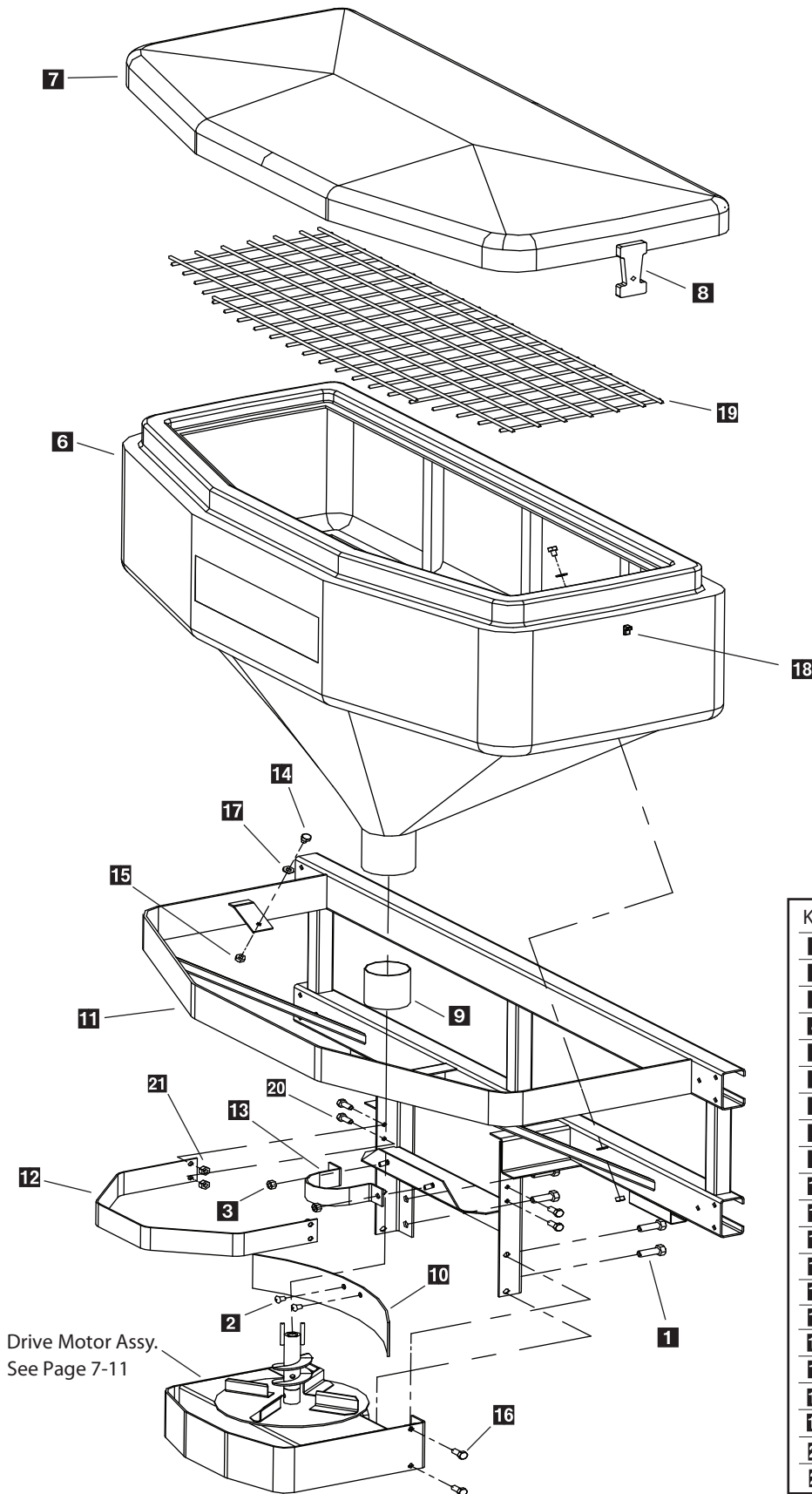

Drive Motor Assy.
See Page 7-11

Key	Part No.	Description	Qty.
1	D 4115	1/2-13 x 1" Hex Bolt (ref. only)	
2	D 6463	Large Plastic Push Pin	2
3	D 6584	3/8-16 Serrated Flg Nut	2
4	D 4124	3/8-16 Lock Nut	6
5	D 4125	3/8" Flat Washer	2
6	D 6262	1075 Hopper	1
7	D 6263	1075 Lid w/Latches	1
8	D 6105	Flexible Draw Latch	2
9	D 6108	Stainless Throat Liner	1
10	D 6110	Deflector 20"	1
11	D 6260	1075 Main Frame	1
12	D 6128	Spinner Guard	1
13	D 6129	Throat Clamp	1
14	D 6137	5/16-18 x 1-1/4 SS Panhead	2
15	D 6394	5/16" Keps Nut	2
16	D 6452	3/8-16 x 1" Ind Hwh Tcs	4
17	D 6169	3/8" SS Washer	2
18	D 6198	Latch Keeper	2
19	D 6261	1075 Top Screen	1
20	D 6133	5/16-18 x 1/2 HHCS	4
21	D 5706	5/16-18 Serrated Flange Nut	4

Parts Breakdown

Model #SP-575

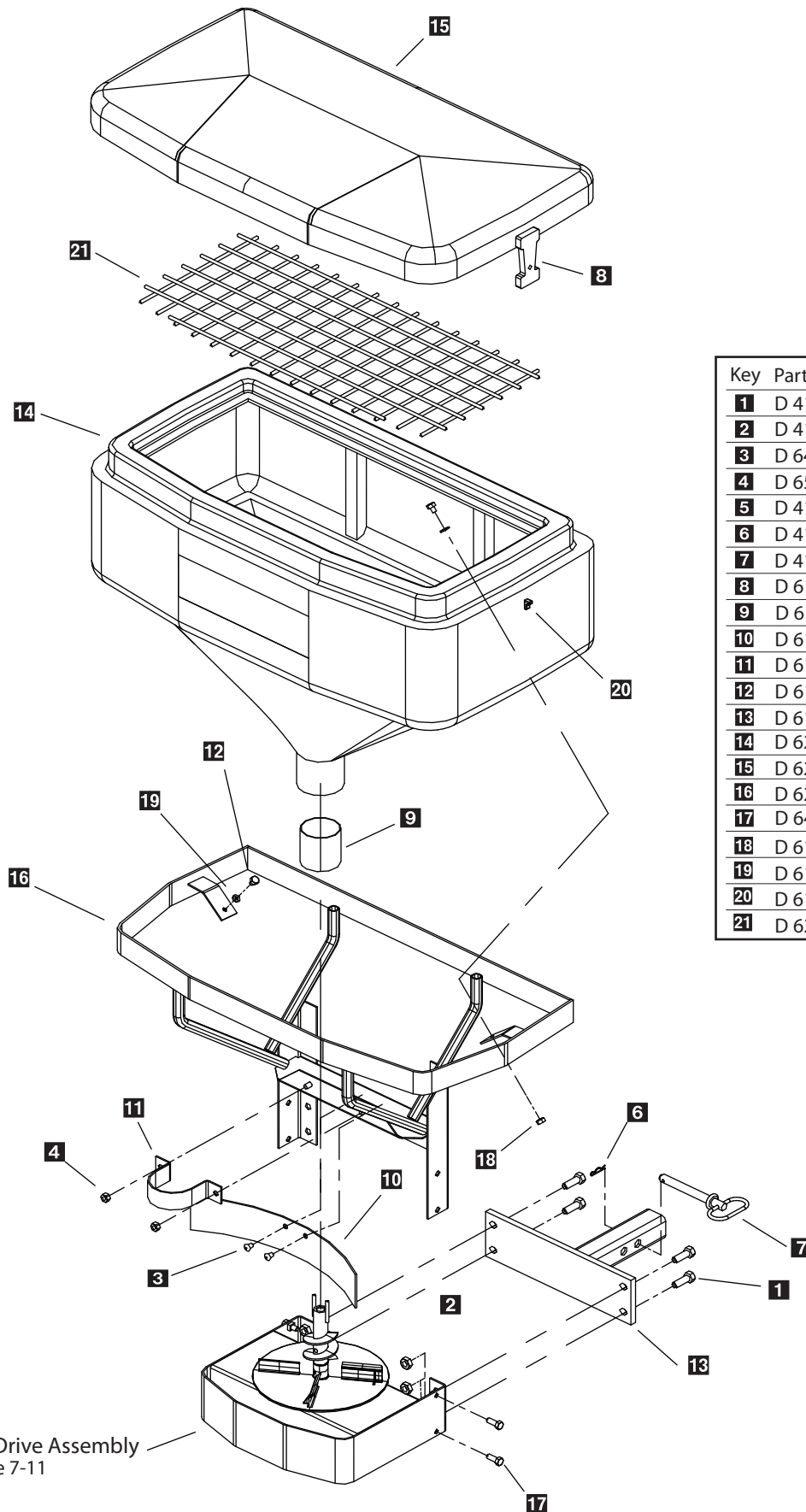

Key	Part No.	Description	Qty.
1	D 4116	1/2-13 x 1-1/2" Hexbolt	8
2	D 4120	1/2-13 Lock Nut	4
3	D 6463	Deflector Push Fastener	2
4	D 6584	3/8-16 Serrated Flg Nut	2
5	D 4125	3/8" Flat Washer	2
6	D 4135	2-5/16 Hair Pin Clip	1
7	D 4136	5/8" x 5-1/2" Hitch Pin	1
8	D 6105	Flexible Draw Latch	2
9	D 6108	Stainless Throat Liner	1
10	D 6110	Deflector 20"	1
11	D 6129	Throat Clamp	1
12	D 6137	5/16-18 x 1-1/4" SS Panhead	2
13	D 6149	2" Receiver Hitch	1
14	D 6239	575 Hopper	1
15	D 6240	575 Lid W/Latches	1
16	D 6245	575 Main Frame	1
17	D 6452	3/8-16 x 1" Ind Hwh Tcs	4
18	D 6168	5/16" Hex Nut	2
19	D 6169	3/8" SS Washer	2
20	D 6198	Latch Keeper	2
21	D 6257	575 Top Screen	1

Motor Drive Assembly
See Page 7-11

Complete Drive Assembly Parts Breakdown



SP-575 – D6117 SP-1075 – D6175

2000 – Current

Key	Part No.	Description	Qty.
1	D 6106	Motor 12 Volt DC	1
2	D 6107	Transmission	1
3	D 6109	Motor Cover	1
4	D 6111	Drive Enclosure	1
5	D 6115	1075 Power Cord	1
5	D 6162	575 Power Cord	1
6	D 6122	Auger	1
7	D 6781	1/2" NPT Plastic nut	1
8	D 6467	Plastic Push Fastener	6
9	D 6131	1/4"-20 x 1/2" Hex Bolt Stainless	4
10	D 6398	3/16 x 1-1/4" Detent Clevis Pin	1
11	D 6122	#10-32 x 5/8" Serrated Flange Bolt	2
12	D 6232	Motor Drive Coupler	1
13	D 6140	5/16-18 x 3/8" Set Screw	1
14	D 6750	10" Injection Molded Spinner	1

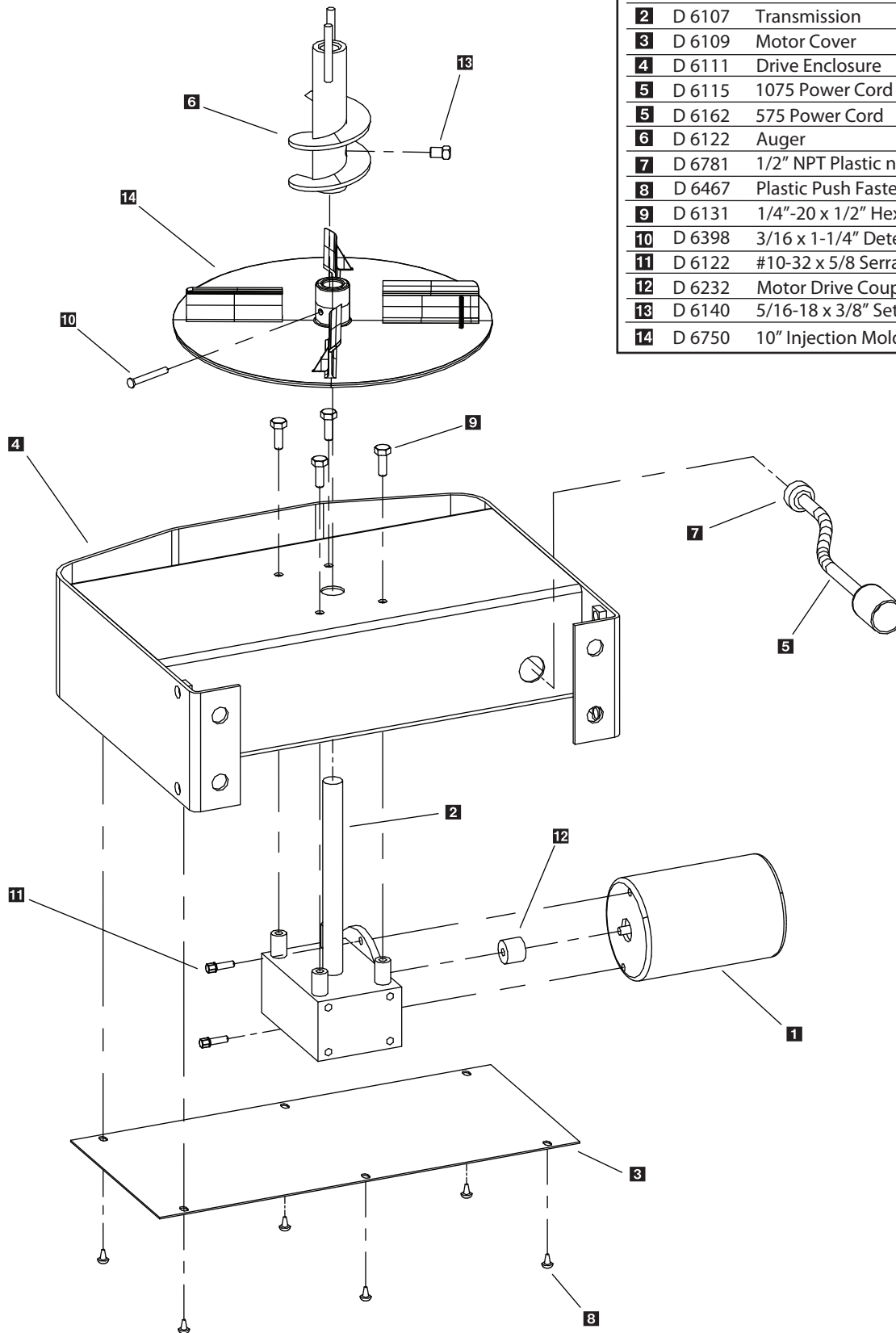

Parts Breakdown

Model #SP-325

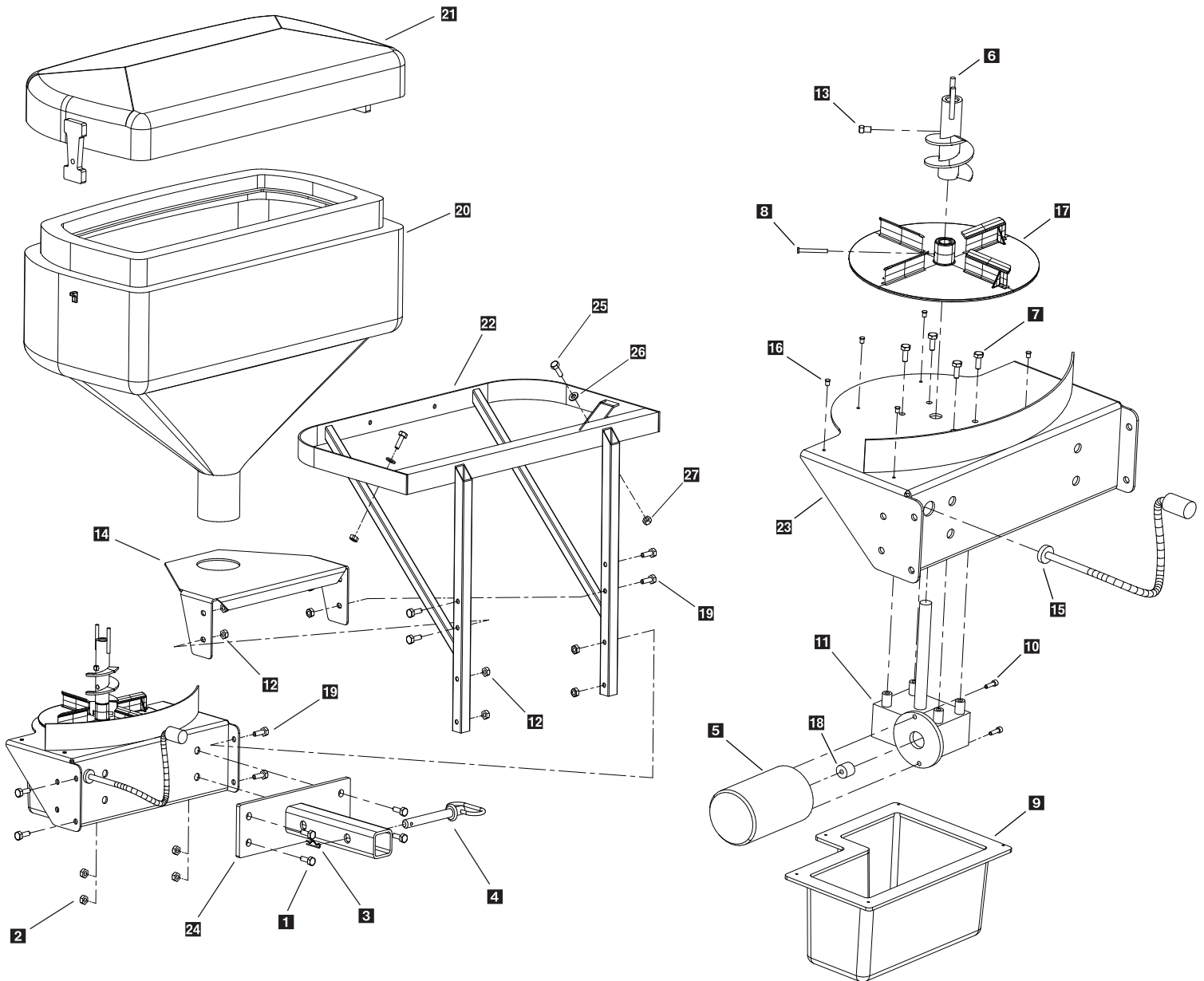

Key	Part No.	Description	Qty.	Key	Part No.	Description	Qty.
1	D 4116	1/2-13 x 1-1/2" Hex Bolt	4	15	D 6162	24" Power Cord	1
2	D 4120	1/2" Lock Nut	4	16	D 6487	#8 x 1/2" Hex Head Sheet Screw	5
3	D 4135	2-5/16" Hair Pin Clip	1	17	D 6750	10" Plastic Spinner	1
4	D 4136	5/8" x 5-1/2" Pin	1	18	D 6232	Motor Drive Coupler	1
5	D 6106	12 VDC Motor	1	19	D 6462	5/16-18 x 1-3/4" HHCS	8
6	D 6122	Hi-Flow Auger	1	20	D 6475	SP-325 Yellow Hopper	1
7	D 6131	1/4-20 x 1/2" Serrated Flange SS	4	21	D 6476	SP-325 Lid Assy	1
8	D 6398	3/16" Pin	1	22	D 6477	SP-325 Frame Weldment	1
9	D 6708	Plastic Bottom Cover	1	23	D 6480	Trans Mount Weldment	1
10	D 6172	10-32 x 5/8" Serrated Flange Bolt	2	24	D 6485	LDM - 175 Lt Duty Rec Mount	1
11	D 6715	14.5:1 Ratio Transmission	1	25	D 6137	5/16-18 X 1-1/4" SS Panhead	2
12	D 6138	5/16 Lock Nut	8	26	D 6169	3/8" SS Washer	2
13	D 6140	5/16 -18 x 1/2" Hex Bolt	1	27	D 6168	5/16-18 Hex Nut	2
14	D 6702	Hopper Support Plate	1				

Mounting Instructions

Model #SP-325



Step 1: Install 2" Receiver Mount to Spreader with supplied hardware. (See parts diagram for more detail)

Step 2: Insert Spreader into 2" Vehicle Receiver Hitch. (Use supplied pin with lock to secure Spreader).

Step 3: Connect Spreader power plug to bumper plug.

Step 4: Read operating Instructions before using spreader.

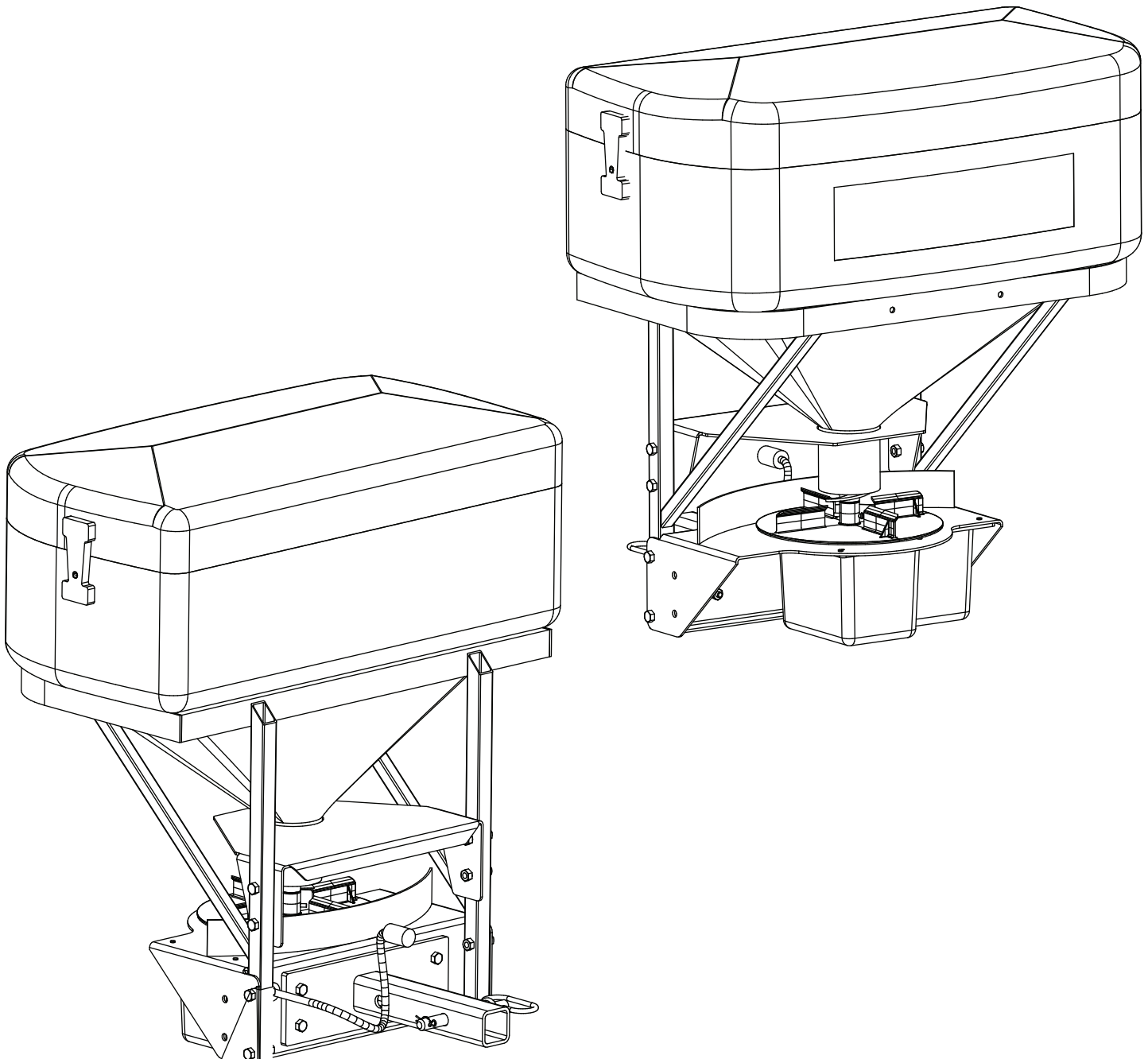

Step 1: Take harness assembly and route from the rear of the vehicle to the front. Route harness along frame and attach to frame holes and frame supports. It is not recommended to attach to fuel or brake lines for obvious reasons. Do not route close to exhaust system or engine, even though Snowex uses high temperature wiring, it still could melt under extreme heat and short the spreader electrical system, as well as the vehicle electrical system.

Step 2: Mount rear plug on bumper using supplied bolts, locate towards the center of the bumper to reduce the amount of debris the tires will throw to the rear. Important: Apply a small amount of dielectric grease to the plug. Also try to mount so plug faces upward to help keep plugs tightly sealed.

Step 3: Secure harness from the rear to the front using heavy duty ty-wraps or frame clips along the frame and lighter duty ty-wraps everywhere else.

Step 4: Layout harness portion that connects to the battery along the fire wall and fender well. Do not connect power leads to battery yet. Drill a 3/4" hole in the fire wall, or use existing access hole, for the control portion of the harness and route connector and harness through hole. Be sure to check the area on the other side of the fire wall to make sure you are not going to drill into the vehicle harness or a control module. Generally you can drill on either side of the steering wheel for a good location.

Step 5: Connect harness to the back of the controller and mount to a suitable location. NOTE: You may want to contact customer before mounting controller, some prefer not to have holes drilled into the dashboard. Ty-wrap loose controller harness and move to the engine compartment. Do not mount close to any heater vents.

Step 6: Connect power leads to the battery: Red + Positive, Black – Negative, always connect to the primary battery if using a dual battery system, secure loose loom to any other large or medium vehicle harness with medium duty ty-wraps; this will secure wiring harness.

Step 7: Push the ON/OFF button on the controller to check for power, when that has been confirmed turn power **OFF**. The electrical portion of the installation is complete.

NOTE: If adding an inline fuse (575 and 1075 only), use a 35 amp slow blow (time delay) or a 35 amp relay.

Wiring Diagram

Model # SP-325

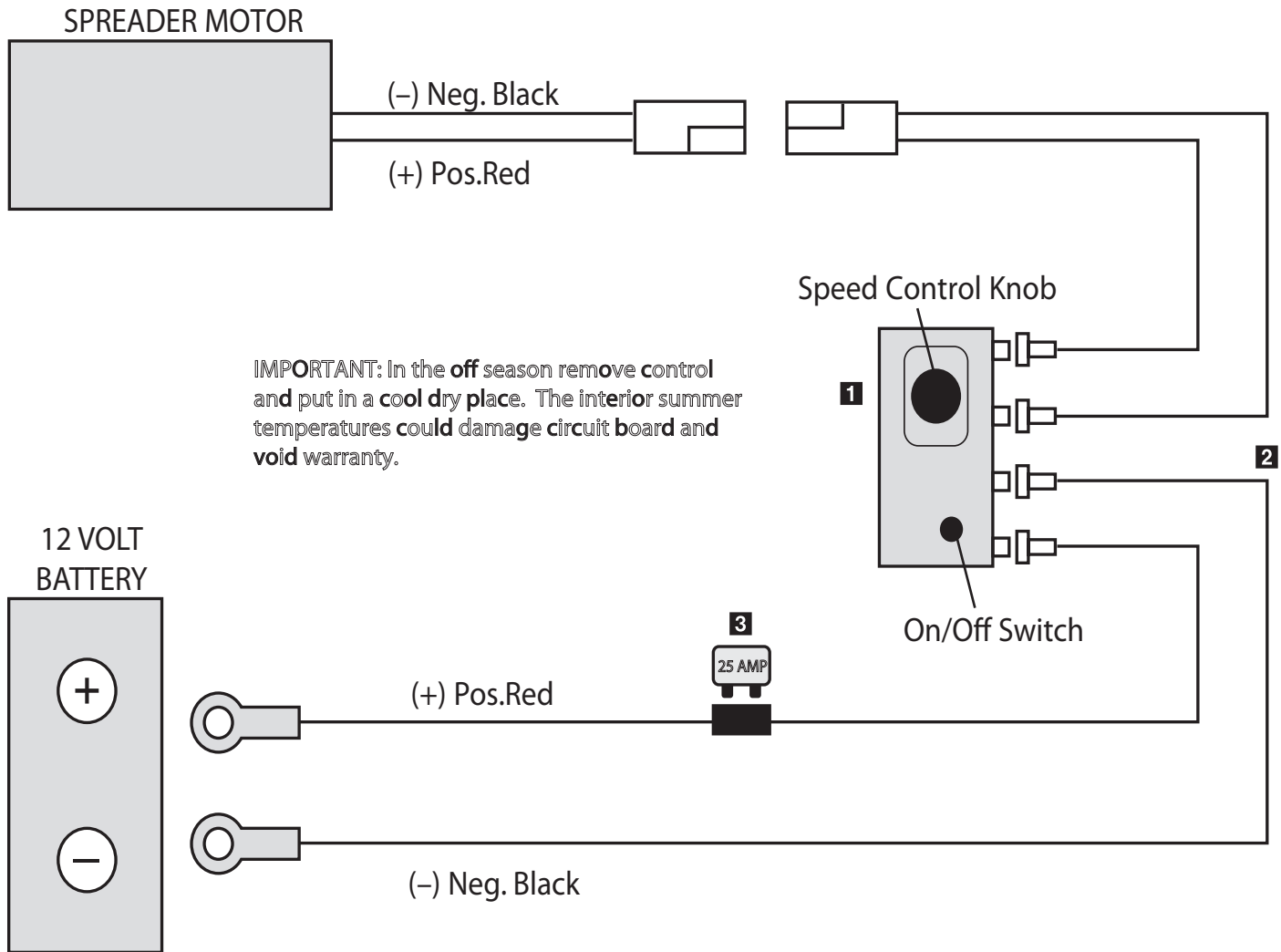

IMPORTANT: In the **off** season remove control and put in a cool dry place. The interior summer temperatures could damage circuit board and void warranty.

IMPORTANT: Do not modify harness length. Any modifications will void warranty.

Special Notes:

1. All external connections must have dielectric grease.
2. Read lead labels before attaching to power source or ground.
3. **No other devices** may be spliced into wiring harness.
4. Any repairs to wiring harness must be done with heat shrink butt connectors.

Key	Part No.	Description	Qty.
1	D 6474	Mini Control	1
2	D 6486	325 Harness	1
3	D 6748	25 Amp Breaker	1

Control and Harness Diagram

Model # SP-1075/SP-575

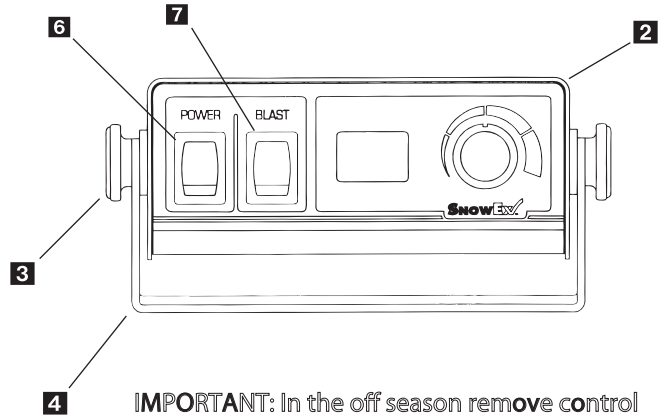
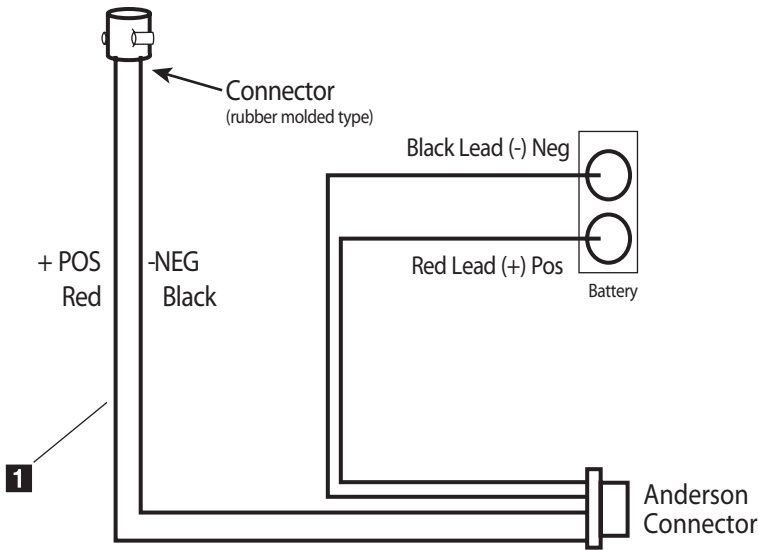

IMPORTANT: In the off season remove control and put in a cool dry place. The interior summer temperatures could damage circuit board and void warranty.

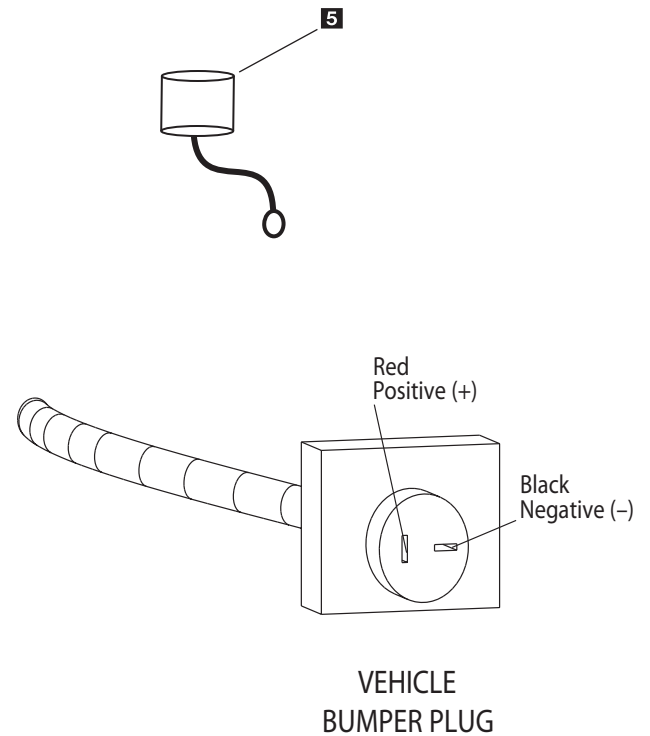
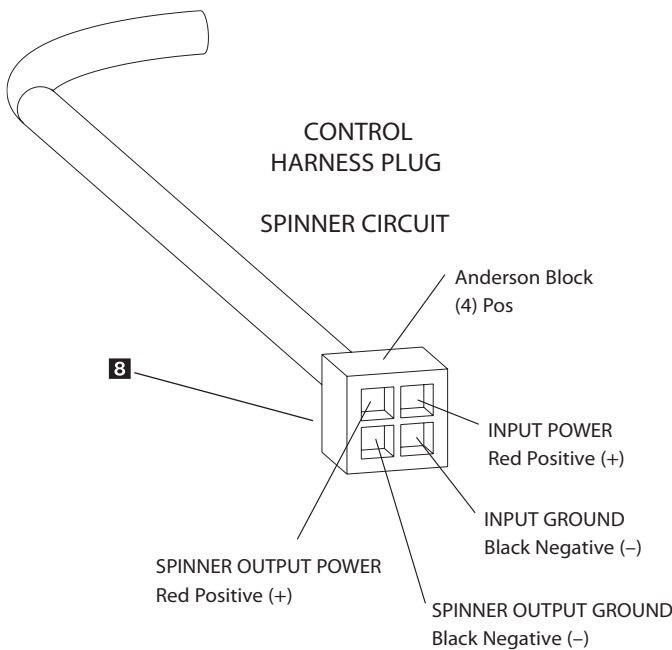

IMPORTANT: Do not modify harness length. Any modifications will void warranty.

Special Notes:

1. All external connections must have dielectric grease.
2. Read lead labels before attaching to power source or ground.
3. **No other devices** may be spliced into wiring harness.
4. Any repairs to wiring harness must be done with heat shrink butt connectors.
5. If inline fuse is installed, use a 35 amp time delay type or a circuit breaker (575 and 1075).

Key	Part No.	Description	Qty.
1	D 6114	Wiring Harness - 24'	1
2	D 6230	1075/575 Variable Speed Controller	1
3	D 6124	Bracket Knob	2
4	D 6123	Controller Mounting Bracket	1
5	D 6118	Dust Cover	1
6	D 6242	3 Terminal Contol Power Switch	1
7	D 6241	Blast Switch	1
8	D 6170	Anderson Connector With Leads	1
	D 6344	Dielectric Grease - 1 1/2 oz. (not shown)	1

Electrical System Parts Breakdown

Model # SP-1875

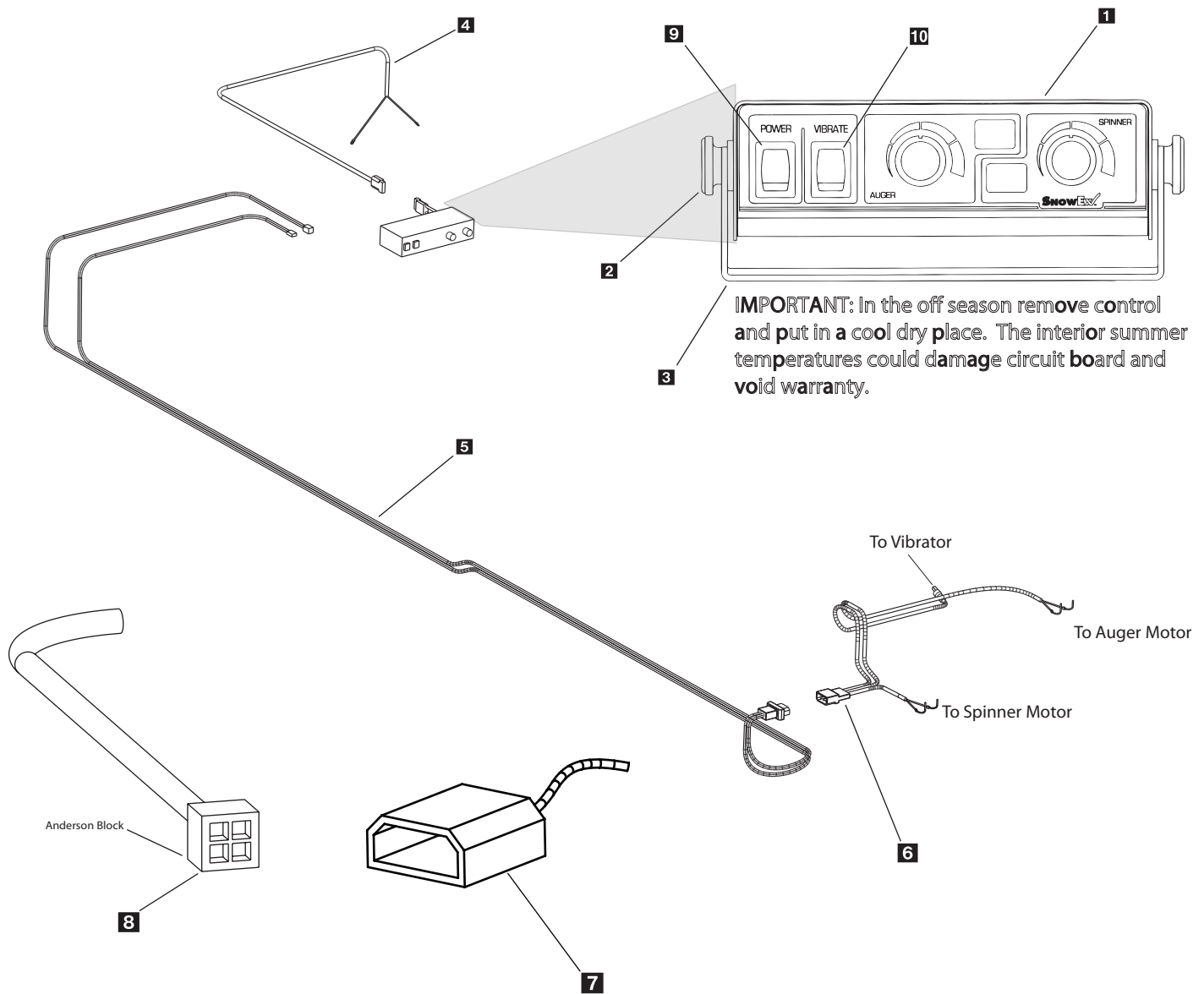

IMPORTANT: In the off season remove control and put in a cool dry place. The interior summer temperatures could damage circuit board and void warranty.

IMPORTANT: Do not modify harness length. Any modifications will void warranty.

Special Notes:

1. All external connections must have dielectric grease.
2. Read lead labels before attaching to power source or ground.
3. No other devices may be spliced into wiring harness.
4. Any repairs to wiring harness must be done with heat shrink butt connectors.
5. If inline fuse is installed, use a 60 amp maxi fuse or circuit breaker.

Key	Part No.	Description	Qty.
1	D 6527	1875 Controller	1
2	D 6124	Bracket Knob	2
3	D 6329	1875 Controller Bracket	1
4	D 6341	Control Power Cable	1
5	D 6322	1875 Wiring Harness - 25'	1
6	D 6321	Power Cord - 48"	1
7	D 6343	Dust Cover	1
8	D 6170	Anderson Connector With Leads	1
9	D 6237	5 Terminal Control Power Switch	1
10	D 6354	3 Terminal Vibrator Switch	1
	D 6344	Dielectric Grease - 1 1/2 oz. (not shown)	1

Vehicle Harness Diagram

Model # SP-1875

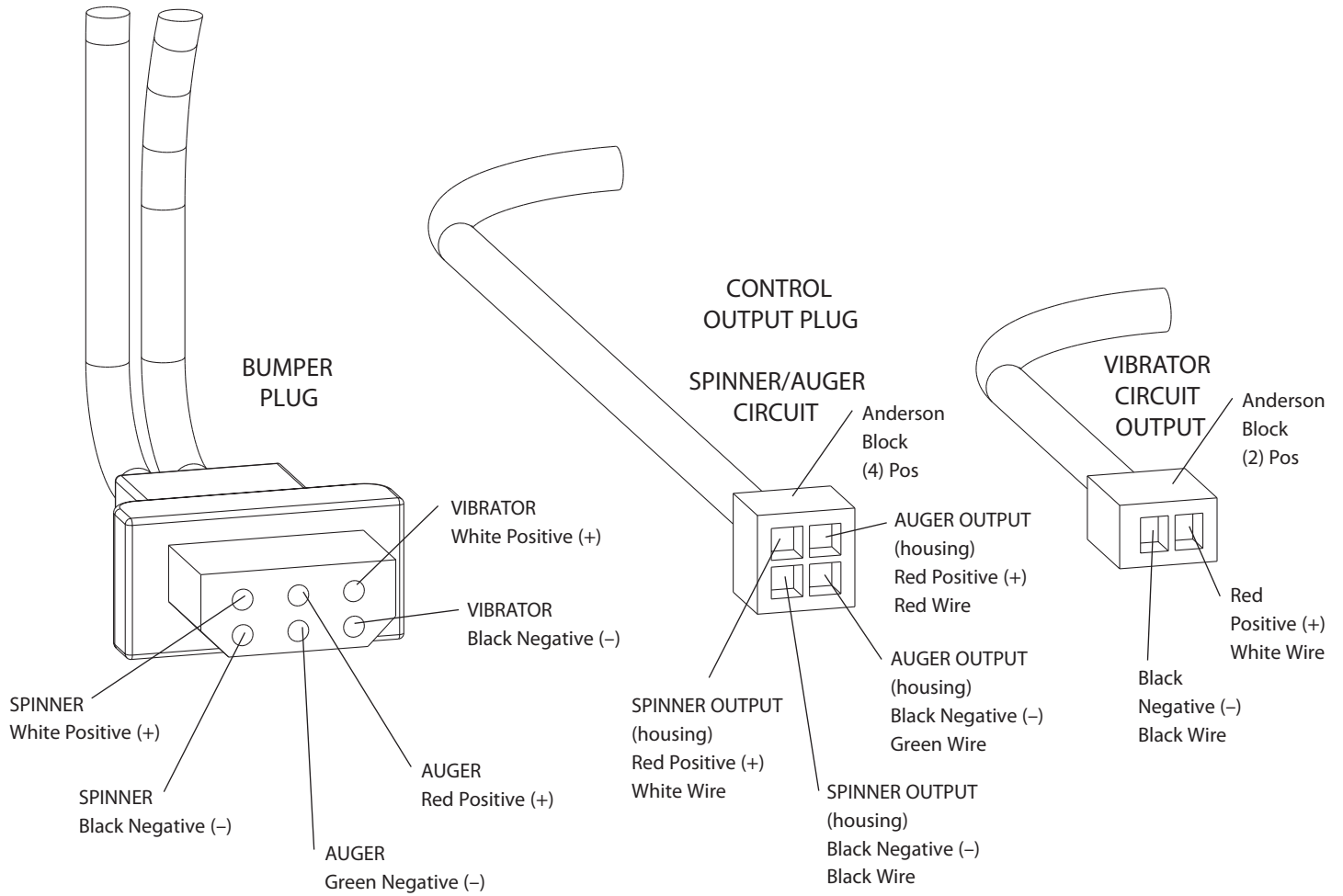

* NOTE: Reference Bumper Plug for Color Code

Spreader Harness Diagram

Model # SP-1875

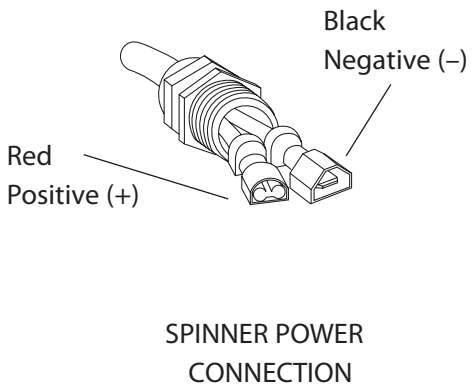
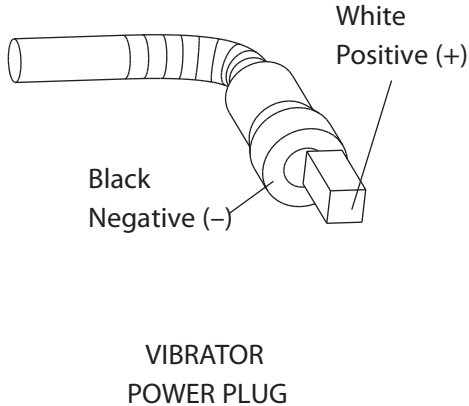
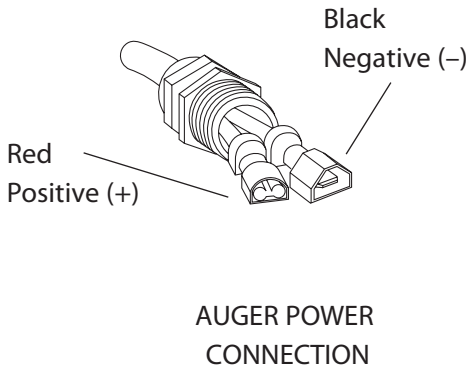
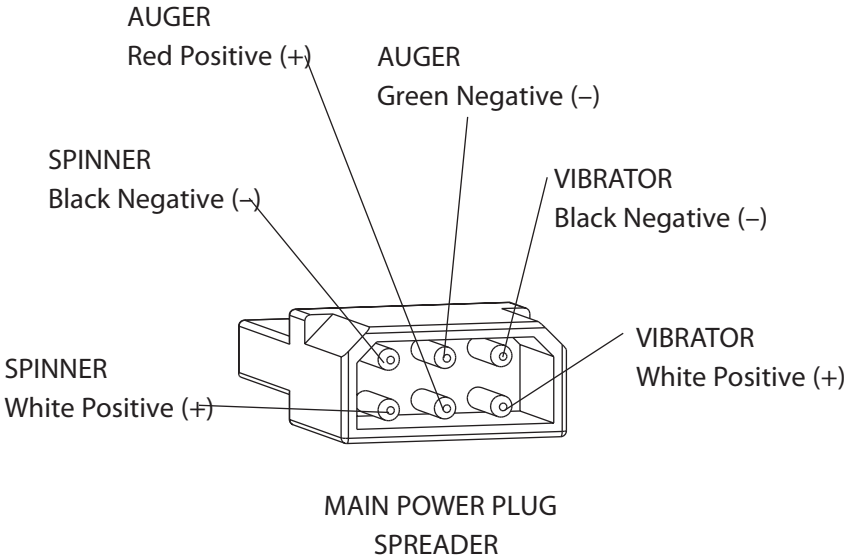

Control Wiring Diagram

Model # SP-1875

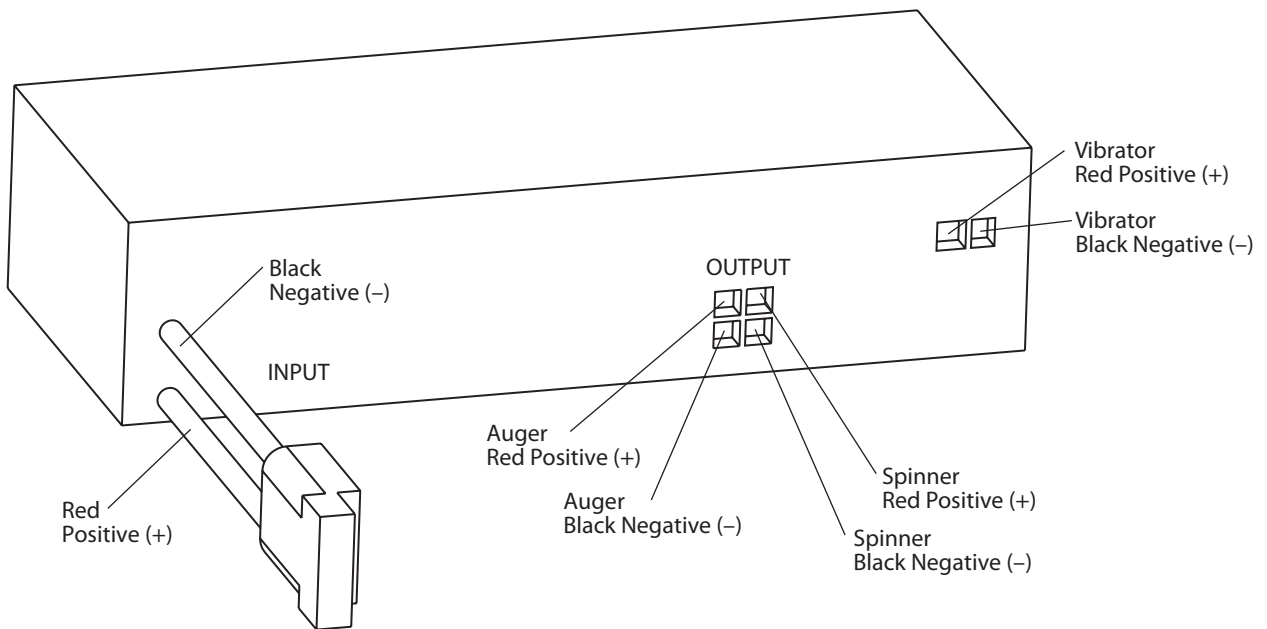

IMPORTANT: In the off season remove control and put in a cool dry place. The interior summer temperatures could damage circuit board and void warranty.

D6341 Control Power Cable

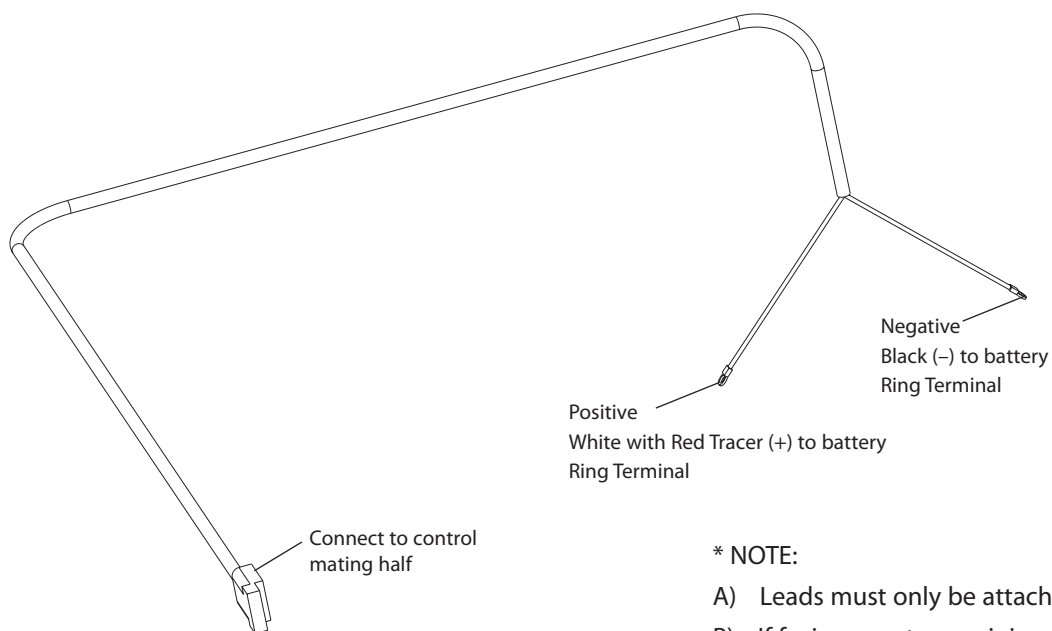

* NOTE:

- A) Leads must only be attached to battery.
- B) If fusing, must use minimum 60 Amp Maxi type fuse or circuit breaker.

THIS PAGE INTENTIONALLY LEFT BLANK

PREPARATION

CAUTION – Sweep area clear of foreign objects or obstacles that could cause personal injury. Keep other persons, children, or animals out of the area to be spread.

SPREADER LOADING

WARNING – Do not overload vehicle. Use chart below to calculate weight of material. Weights of material are an average for dry materials.

Material	Weight Per Cubic Ft.
Rock Salt	75-85 lbs.
Sand/Salt Mix	95-120 lbs.

- Be sure to comply with manufacturer's maximum gross vehicle weight ratings.
- Warning – Never leave materials in hopper for long periods of time as salt is hygroscopic and will attract atmospheric moisture and harden up. When spreading sand mix, a 1:1 ratio for Sand/Salt mix is recommended to prevent the material from freezing.

SPREADING TIPS

- Never exceed 10 m.p.h. when spreading.
- For a wider pass, increase spinner speed.
- For a heavier pass, drive slower, or increase auger speed.
- Never operate spreader near pedestrians.
- Spread ice melters with the storm to prevent unmanageable levels of ice.
- Calculate spread pattern when near vegetation.

LICENSE PLATE INSTALLATION FOR (325,575,1075,1875 if required by local laws)

- You will need (2) 1/4-20 x 1/2" machine screws along with nylock type nuts.
- Install license plate with hardware to mounting holes provided in hopper apron.
- See illustration below.

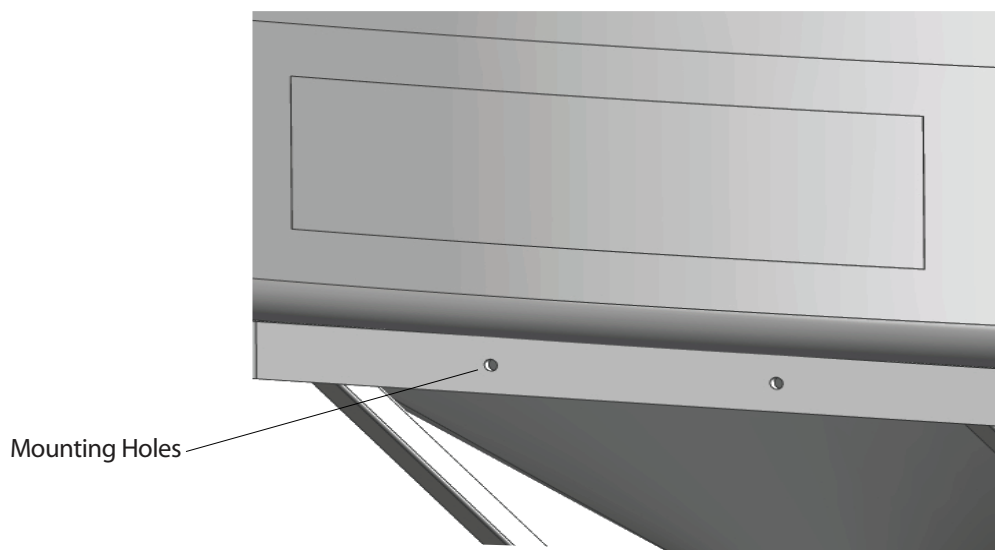

Continued

SPREADER OPERATION

PIVOT-PRO 1075 / MINI-PRO 575

- The variable speed controller has finger-tip dial action, digital system status with warning protection and blast feature.
- To start, press power switch on controller and spreader will accelerate to speed set on dial.
- To stop, press power switch on controller to off position.
- Adjust speed of spinner by using dial on right side of controller.
- If more salt is needed in certain areas, press the blast switch to give maximum power.

BULK-PRO 1875

- The Dual Variable Speed Control has dual finger-tip dials for maximum performance, digital system status with warning protection and built-in Vibrator Switch.
- To start, press power switch on controller and spreader will accelerate to speed set on spinner and auger dials.
- To stop, press power switch on controller to off position.
- Speed of auger and spinner may be adjusted separately to get desired flow and spread distance from spreader.
- The Vibrator Switch is needed for dense material or to increase the flow to the auger. This eliminates bridging of material in hopper.
- A Material Baffle (Part #D6330) has been installed in your spreader to stop fine material from free-flowing. If using dense or damp material, or if more flow is desired, remove Material Baffle. However, it is recommended that the Material Baffle remain in place if using bulk salt.
- It is important that the Inverted Vee (Part #D6328) not be removed except when servicing.

AUTO-REVERSE "AR" FUNCTION (BULK-PRO 1875 ONLY)

- If your controller displays "OL" this could indicate a jammed auger.
- To engage the Auto-Reverse "AR" function:
 - Step 1: Shut the Main Power Switch OFF for 3 seconds.
 - Step 2: Turn the Main Power Switch ON. When the machine starts back up the "AR" sequence will automatically start and the auger will reverse for several rotations to clear the jam.
- After a pause of several moments, the auger will automatically return to correct rotation.
- If the jam is still not cleared, the controller will again display "OL".
- You may repeat Steps 1 & 2 for a second and third time.
- If after the third try the controller displays "OL" — you must extract the material that is causing the problem.
- Follow all warning directions when clearing jams.

WARNING PROTECTION

- If audible beeping occurs, read display to identify problem. If display reads "OL" (overload) or "OH" (overheat), shut controller down and carefully clear jammed auger. If display reads "E1" this means there is a dead short in system. Do not use until problem is corrected. If display reads "E0", this means that the motor is not getting any power. Check all connections. If display reads "LB", the vehicle battery is extremely low and could damage system or a poor connection exists.
- If there are any problems while operating the spreader, refer to Troubleshooting Guide.

Adjustable Deflector Parts Breakdown

Model #ADF-020 For SP-575 and SP-1075

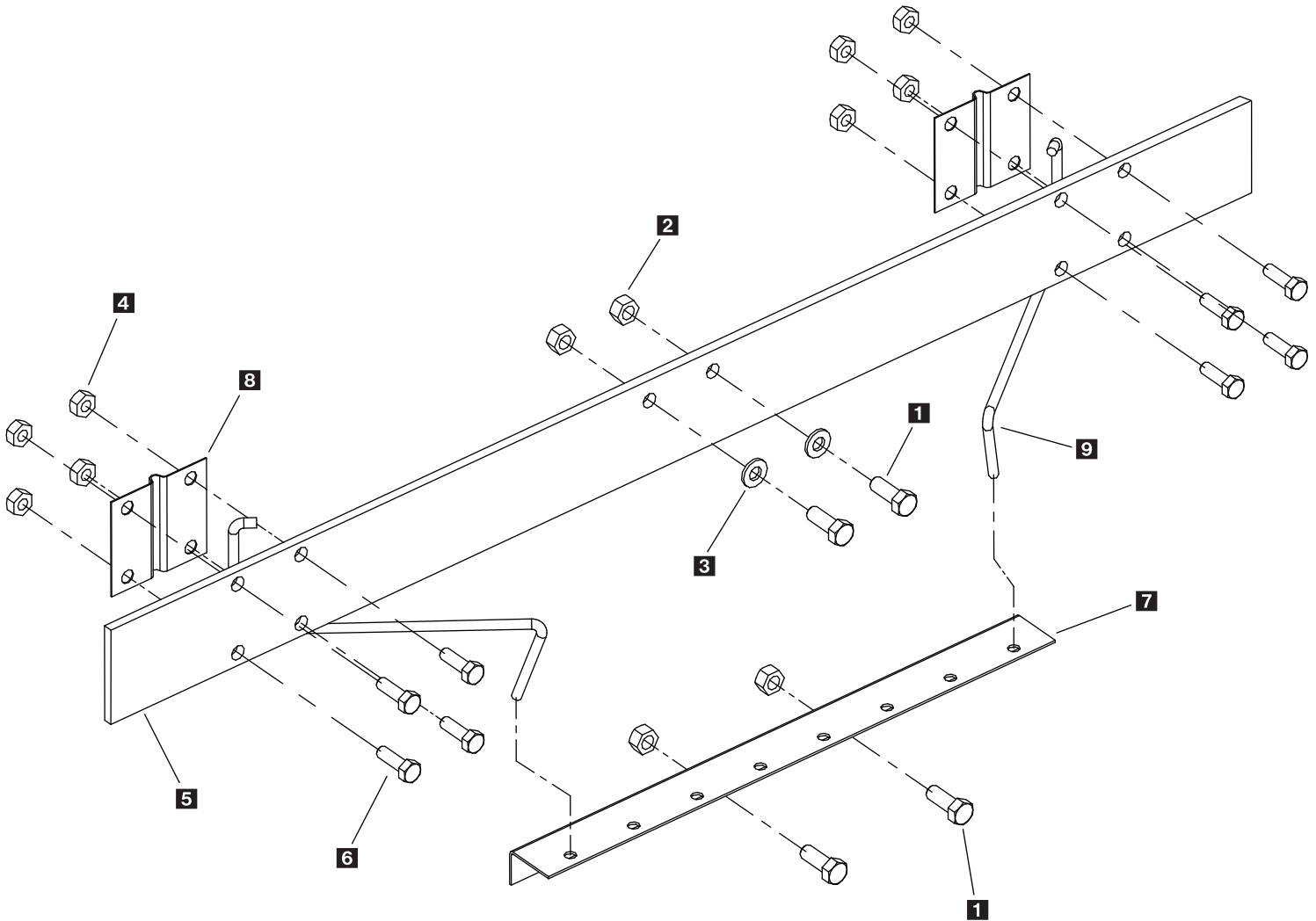

Key	Part No.	Description	Qty.
1	D 4121	3/8" - 13 x 1" Hex Bolt	2
2	D 4124	3/8" - Locknuts	2
3	D 4125	3/8" - Flatwashers	2
4	D 6138	5/16" - 18 Locknut	10
5	D 6154	36" Deflector	1
6	D 6166	5/16" - 18 x 1" Hex Bolt	10
7	D 6179	Deflector Adjustment Bracket	1
8	D 6180	Adjustment Bar Mounting Bracket	2
9	D 6181	Adjustment Bar	2

Adjustable Deflector Installation Instructions

Model #ADF-020 For SP-575 and SP-1075

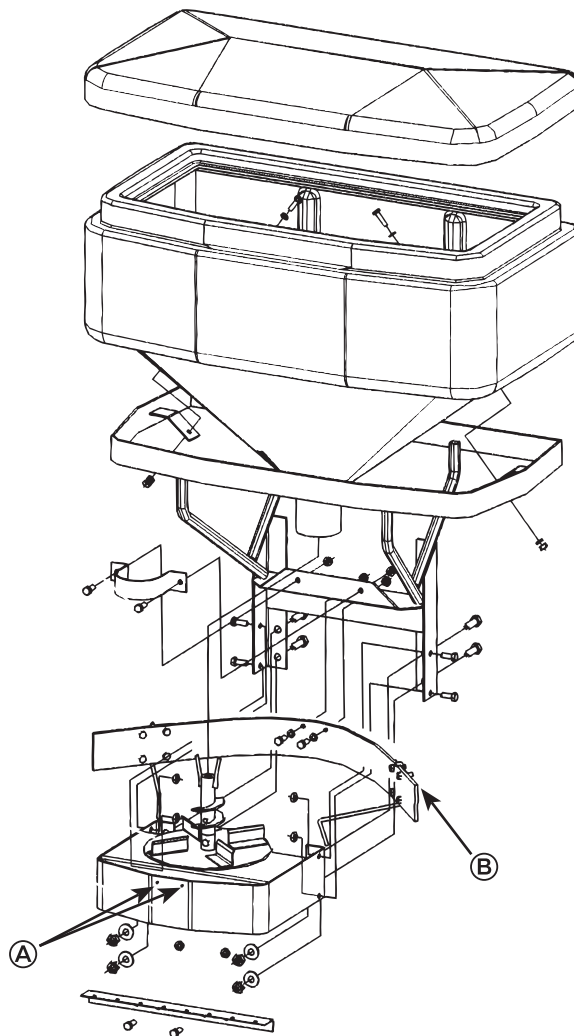

SPREADER ASSEMBLY (575 Shown)

INSTALLATION

Step 1: Install deflector adjustment bar as seen in Figure A. If needed, drill two 3/8" holes in front apron of drive enclosure. Bolt bracket to drive enclosure.

Step 2: Remove original deflector.

Step 3: Mount adjustment bar and mounting bracket on back side of 36" deflector. See Figure B.

Step 4: Install 36" deflector assembly.

OPERATION

Step A: To adjust deflector position, simply insert adjustment bars into holes on deflector adjustment bracket until desired spread pattern is achieved.

Gate Assembly Kit Parts Breakdown

Model #GAK-020 for SP-575 and SP-1075

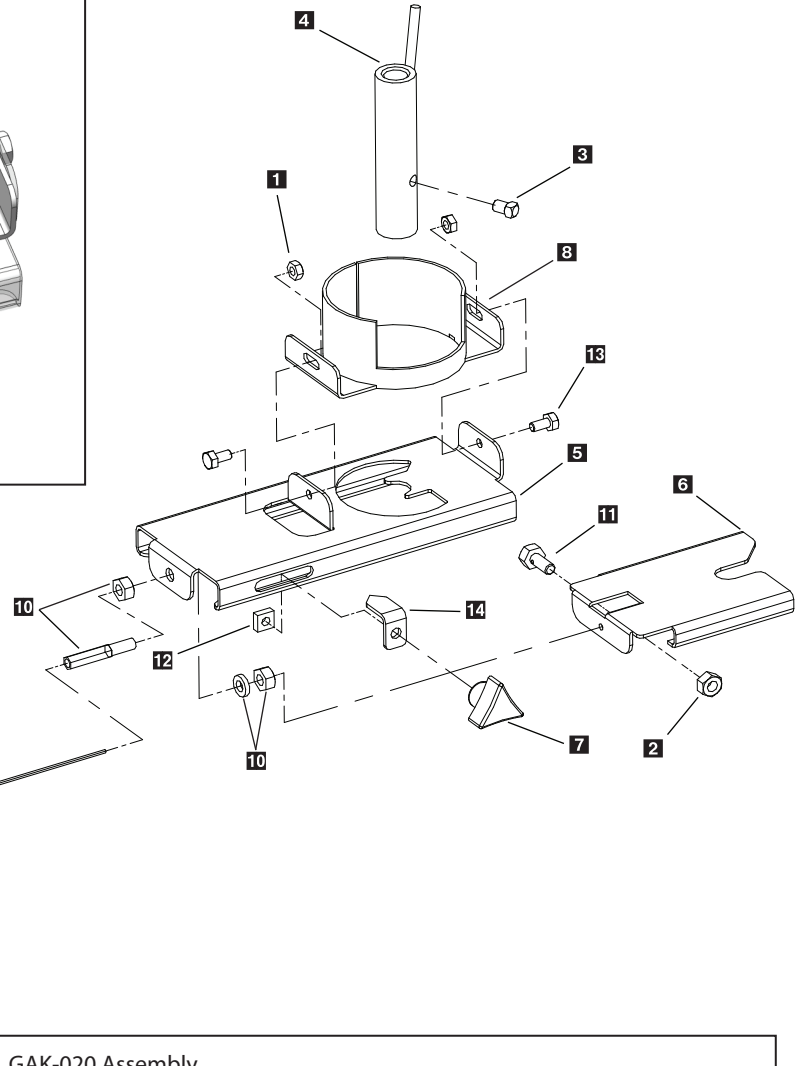
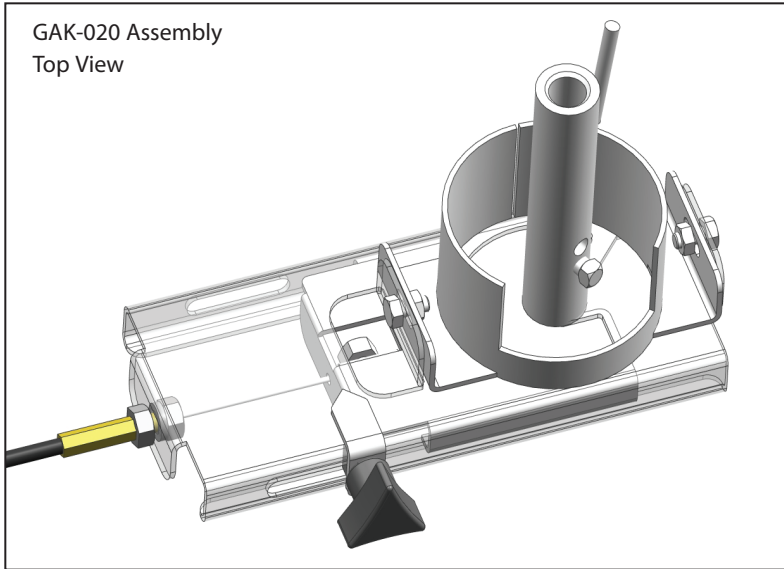

Key	Part No.	Description	Qty.
1	D 4289	1/4" Lock Nut	2
2	D 6138	5/16" Lock Nut	1
3	D 6140	5/16" Set Screw	1
4	D 6185	Agitation Auger	1
5	D 6365	SS Gate Body	1
6	D 6366	SS Gate Slide	1
7	D 6302	Gate Knob	1
8	D 6367	SS Throat Mount	1
9	D 6304	10' Cable	1
10	D 6305	Cable Fitting Assy	1
11	D 6308	5/16" - 18 Special Bolt	1
12	D 6309	Knob Square Nut	1
13	D 6311	1/4 - 20 x 1/2" Hex Bolt	2
14	D 6368	SS Gate Stop Indicator	1
15	D 6351	Cable Mounting Bracket	1

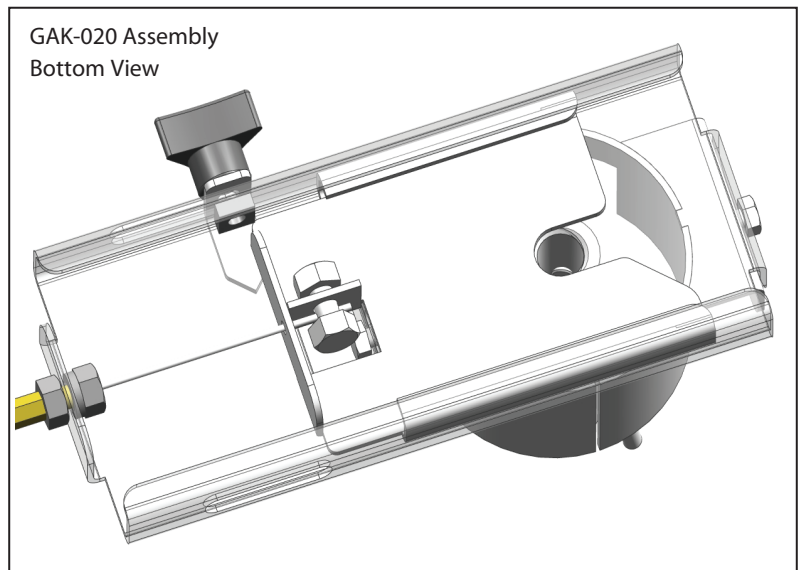

Gate Assembly Kit Instructions



Model # GAK-020

INSTALLATION INSTRUCTIONS

Step 1: Remove hopper by taking out the two 5/16" stainless steel bolts located inside the hopper.

Step 2: Remove throat clamp using a 9/16" wrench or socket.

Step 3: Remove auger using allen key. NOTE: Do not re-install when using gate assembly kit.

Step 4: (Optional) Next determine how long your cable should be. Once you have determined the length, pull control wire back 3" from your cut off point. This will allow you to travel in your gate control.

Step 5: Thread the brass bulk head connector onto the cable jacket. Then install this assembly onto the gate using the supplied drawing.

Step 6: You can now place the gate assembly on to the shaft and position it so that the cable actuator is on the left side if you are looking at it from the back. Leave the gate body and throat mount loose.

Step 7: Now install the new agitator positioning it so that the bolt is on the upper most part of the shaft flat. Use a small amount of blue locktite on the bolt before tightening.

Step 8: At the same time place the hopper back into the frame and slip the gate throat mount over the hopper throat. NOTE: You may need to trim hopper throat for spinner clearance.

Step 9: Place the 5/16" stainless bolts back into the hopper and tighten.

Step 10: Push the gate control up as far as it will go. This will make sure the gate and the spinner will not make contact. Also make sure the gate throat mount is between the hopper throat and the hopper throat clamp. This will help keep it in position when you begin to tighten the throat clamp bolts.

Step 11: Take the throat clamp and reinstall making sure that you will be making full contact with the gate throat mount.

Step 12: You now can tighten the gate throat mount to the gate body. Make sure that the shaft is centered front to back. If not, move the gate body until desired location is determined and tighten bolts on the gate throat mount.

Step 13: Install gate positioning knob into gate slotted opening.

Step 14: When gate has been properly positioned to desired location, drill a 1/4" hole and install a sheet metal screw or a pop rivet to ensure gate will not move from the optimum location.

OPERATING INSTRUCTIONS

Position the gate locking knob to the desired setting. This will give you a positive reference point for consistent operation. You will need to look into the hopper with the gate open to get an idea of where to locate the stop.

When using a variable speed controller, you may need to open the gate slightly more than you would if using a standard on/off control.

Once you have determined the gate position, you can then load the hopper with material and perform a test run. A parking lot or paved area is the best way to analyze your pattern. This will assist you in tuning your spreader and material to the specific task.

SPECIAL INSTRUCTIONS

NOTE: If there is insufficient space between the spinner and gate (at least 1/2"), the hopper throat should be trimmed back 1/2".

Step 1: Using a ruler, scribe a line 1/2" up from the bottom edge of the throat with a black permanent type marker.

Step 2: Using a hacksaw or sawsaw type tool, cut around the hopper throat along the line that was scribed. When you have completed this, trim away any loose material around edges using sandpaper or a razor knife.

Wiring Diagram and Instructions

Model # VBR-080

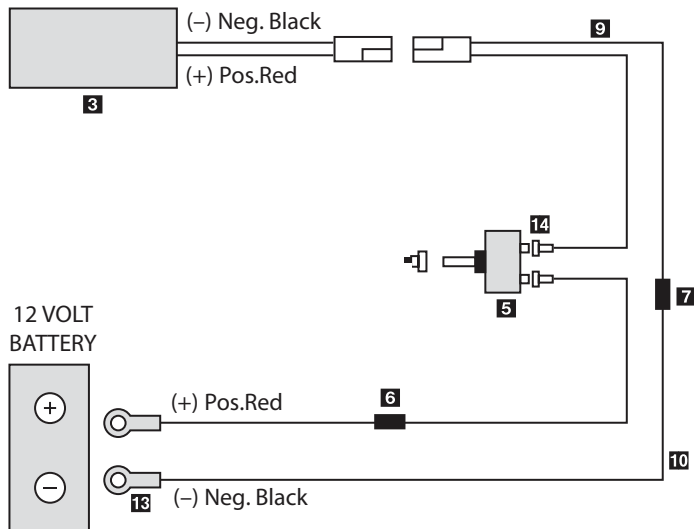

Key	Part No.	Description	Qty.
1	D 4124	3/8" Lock Nut	4
2	D 6160	3/8" - 16x2 Hex Bolt	4
3	D 6161	DC-80 Vibrator	1
4	D 6579	Vibrator Backing Plate	4
5	D 6184	On/Off Switch	1
6	D 6233	10 Amp Fuse	1
7	D 6234	Butt Connector	1
8	D 6344	Dielectric Grease	1
9	D 6403	20' Universal Harness	1
10	D 6404	10' Battery Harness	1
11	D 6406	Rubber Switch Boot	1
12	D 6425	Fuse Holder	1
13	D 7105	Ring Terminal	2
14	D 7106	Spade Connector	2

Wiring Installation and Instructions

Step 1: First, install switch at desired location. This will determine what the proper wire length should be.

Step 2: Run spreader/vehicle harness from the rear of vehicle to switch area. Remove approx. 3" of the black outer jacket exposing two single leads (red and black), strip a 1/4" off each lead. Crimp 1/4" female connector on red lead and crimp the butt connector to the black lead. Place the female spade/red wire to the on/off switch and leave the black wire for the next step.

Step 3: Route the power harness from the battery to the switch; this will determine proper length to cut wires. Repeat step #2 regarding cable jacketing and connection points to the switch and butt connector.

Step 4: Install an inline 10 amp. fuse on the positive (red) lead from the battery to the switch. Locate an easily accessible place, out of the elements, for the fuse and remove approx. 3" of the black outer jacket exposing two single leads (red and black). Cut the red lead in half and strip a 1/4" off each lead. Insert into the fuse connector and crimp. Insert 10 amp. blade fuse into connector.

Step 5: At the battery end of the power harness, remove 8" of the black outer jacket exposing two single leads (red and black). Strip 1/4" off each lead. Crimp a 3/8" lug terminal to each lead and attach the red lead to the positive side of the battery and the black lead to the negative side of the battery.

Step 6: Locate vibrator approx. 6" to 8" from the top of throat entry and drill four 3/8" holes in rear hopper face. Bolt the vibrator in place using bolts provided, with backing plate inside the hopper.

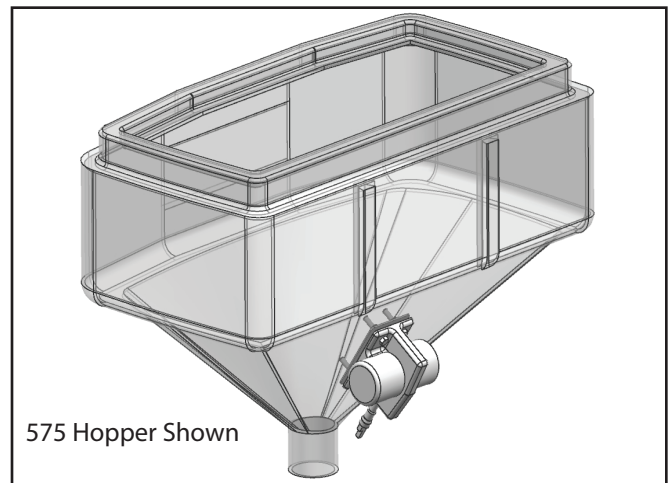

IMPORTANT: It is imperative that the vibrator backing plate is used, see page 7-29 for more details.

Vibrator Parts Breakdown



Model # VBR-080

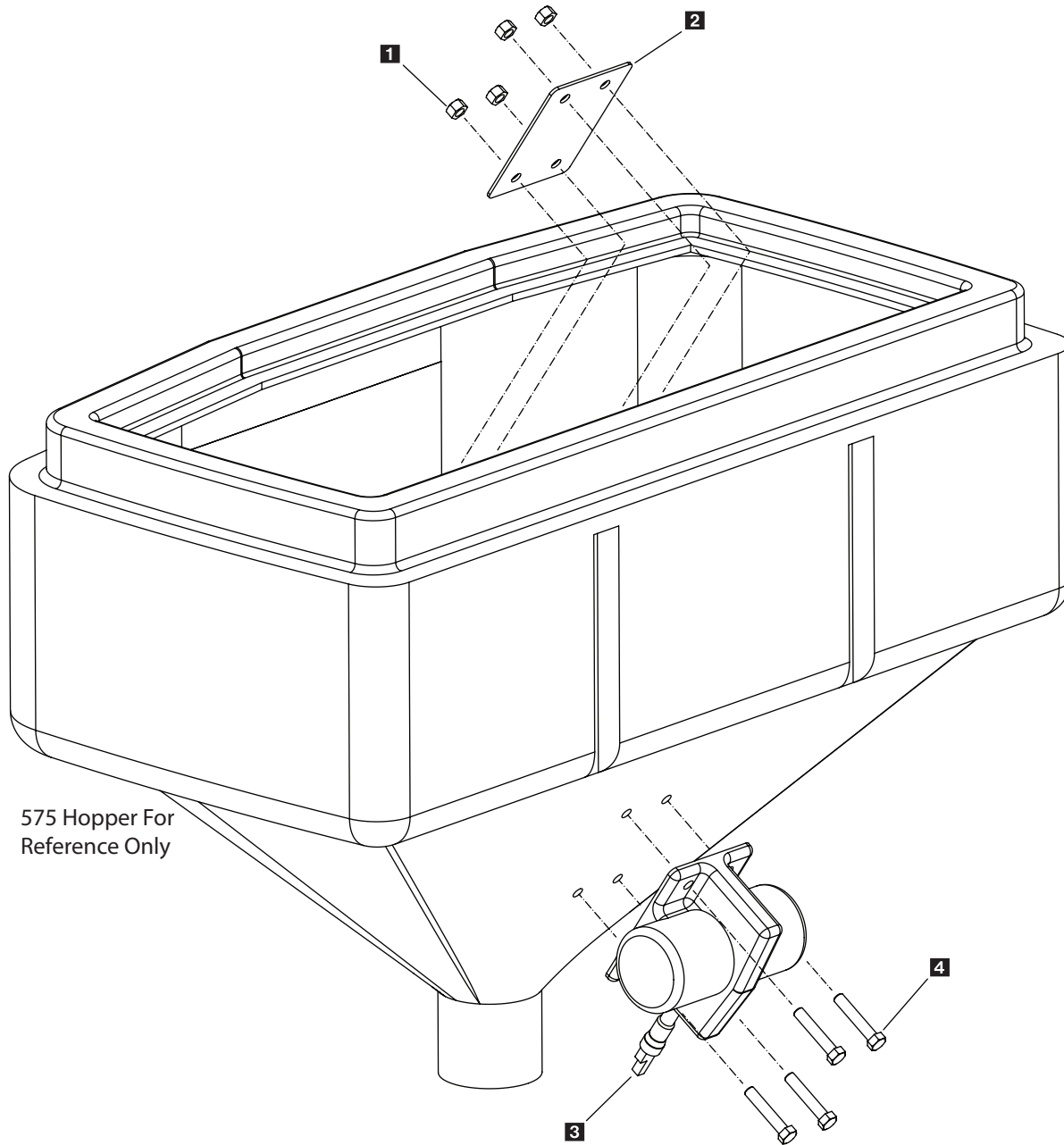

Key	Part No.	Description	Qty.
1	D 4124	3/8" Lock Nut	4
2	D 6579	Vibrator Backing Plate	1
3	D 6161	DC-80 Vibrator	1
4	D 6160	3/8" - 16x2 Hex Bolt	4

Receiver Hitch Mount Parts Breakdown

Model #RHT-375



Shown with SP-1075 configuration

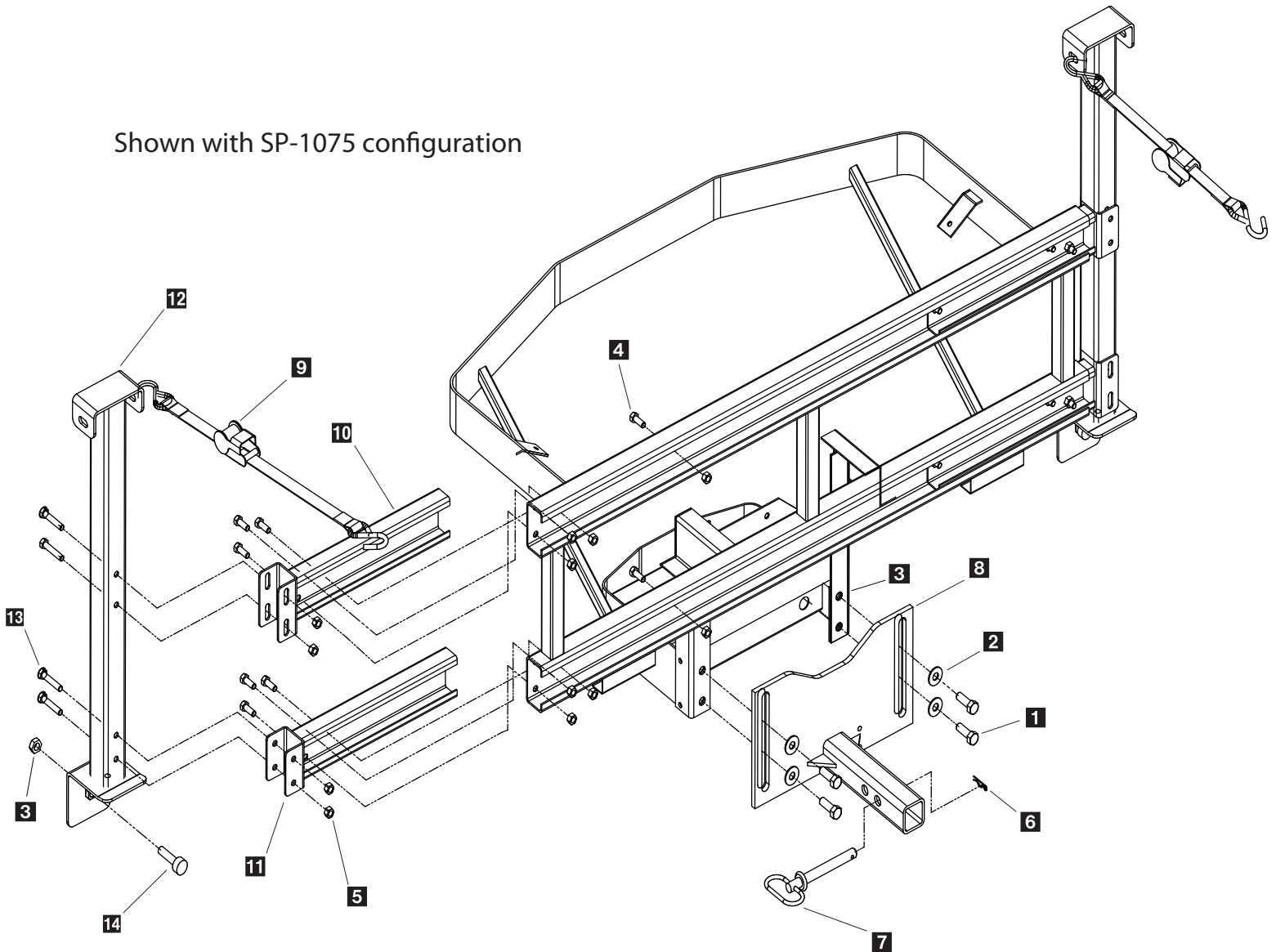

Key	Part No.	Description	Qty.
1	D 4116	1/2-13 X 1-1/2" Hex Bolt	4
2	D 4119	1/2" Flat Washer	4
3	D 4120	1/2" Lock Nut	6
4	D 4121	3/8-16 x 1" Hex Bolt	16
5	D 4124	3/8" Lock Nut	24
6	D 4135	2-5/16" Hair Pin Clip	1
7	D 4136	5/8" x 5-1/2" Hitch Pin	1
8	D 6270	2" Receiver Weldment	1
9	D 6503	Ratchet Strap	2
10	D 6386	Upper Rail Weldment	2
11	D 6387	Lower Rail Weldment	2
12	D 6388	Vertical Rail Support	2
13	D 6392	3/8-16 x 3" Tap Bolt	8
14	D 6791	1/2-13 x 2" Non-Skid Leveling Pad	2

Receiver Hitch Mount Mounting Instructions



Model #RHT-375

- Step 1: Insert Upper and lower channels items **10**, **11** for both the left and right sides. Assemble rails to frame using supplied 3/8" hardware. See illustration on pg. 7-29 for a more detailed view.
- Step 2: You will notice a fourth hole in each rail towards the center of the spreader; we recommend drilling this hole through the frame and securing with supplied hardware. This will add additional strength to the spreader frame.
- Step 3: Next insert 2" receiver plate **8** into hitch and install pin to locate; remove existing 4 rear 1/2" bolts from spreader drive assembly.
- Step 4: With assistance, lift spreader onto bumper and re-install 1/2" bolts through receiver plate into frame; re-install lock nuts but leave slightly loose.
- Step 5: Locate upright supports and bolt to frame rails using 3/8" hardware, see illustration on pg 7-29 for a more detailed view.
- Step 6: With assistance lift spreader onto bumper, attach spreader to frame using the existing bolts that were removed in step 3.
- Step 7: Tighten receiver mount bolts.
- Step 8: INSTALL BOTH RATCHET STRAPS FROM THE FRAME SUPPORT WELDMENT TO AN IN BED TIE DOWN POINT.

Model #RHT-085 Adapter Kit

- Step 9: Place item **2** frame adapter on the back lower inside rail face, place item **3** on the outside back lower rail (see illustration). Install hardware for items **2** & **3** as shown in the exploded view. Refer to figures 1 & 2 for proper installation.
- Step 10: Insert 2" receiver weldment item **8** (pg 29) into hitch and install pin to locate.
- Step 11: With assistance, lift spreader onto bumper.
- Step 12: Install 1/2" bolts through receiver weldment item **8** (pg 29) into frame adapter item **2**.
- Step 13: Tighten receiver mount bolts.
- Step 14: USE BOTH RATCHET STRAPS FROM EACH SIDE OF THE FRAME SUPPORT WELDMENT TO AN IN BED TIE DOWN OR WITH A SINGLE STRAP, FROM SIDE TO SIDE AROUND BOTH FRAME SUPPORT WELDMENTS.

Receiver Hitch Mount Parts Breakdown



Model #RHT-375 / RHT-085 ADAPTER KIT

Shown with 1875 configuration

See pg. 7-29 for RHT-375 main part numbers and descriptions.

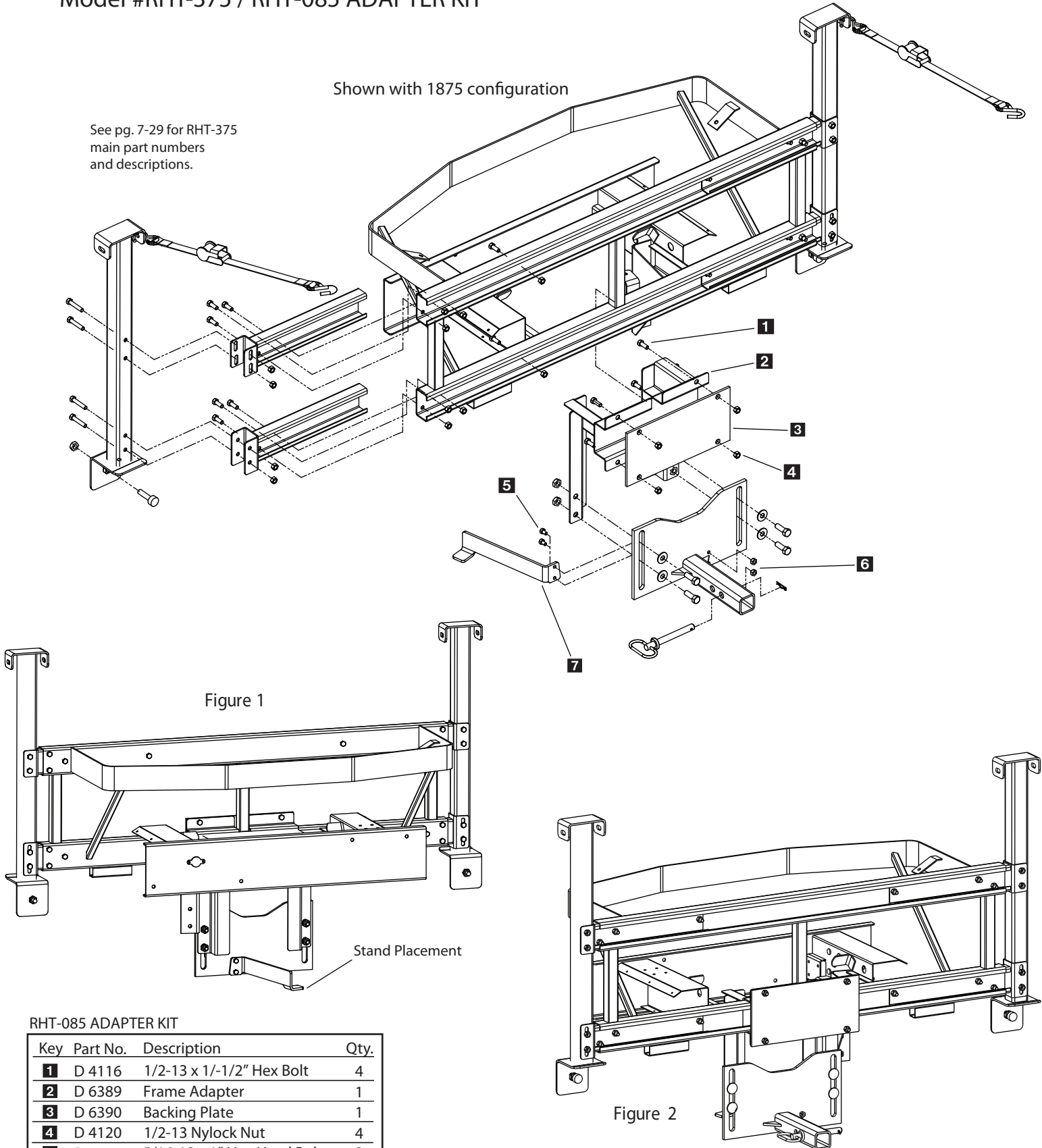

Figure 1

Figure 2

RHT-085 ADAPTER KIT

Key	Part No.	Description	Qty.
1	D 4116	1/2-13 x 1/-1/2" Hex Bolt	4
2	D 6389	Frame Adapter	1
3	D 6390	Backing Plate	1
4	D 4120	1/2-13 Nylock Nut	4
5	D 6166	5/16-18 x 1" Hex Head Bolt	2
6	D 6138	5/16-18 Nylock Nut	2
7	D 6393	Stand	1

Pivot Mount Parts Breakdown

Model #PMT-175

NOTE: See Installation Warning (Packaged with Kit) Before Drilling Holes.

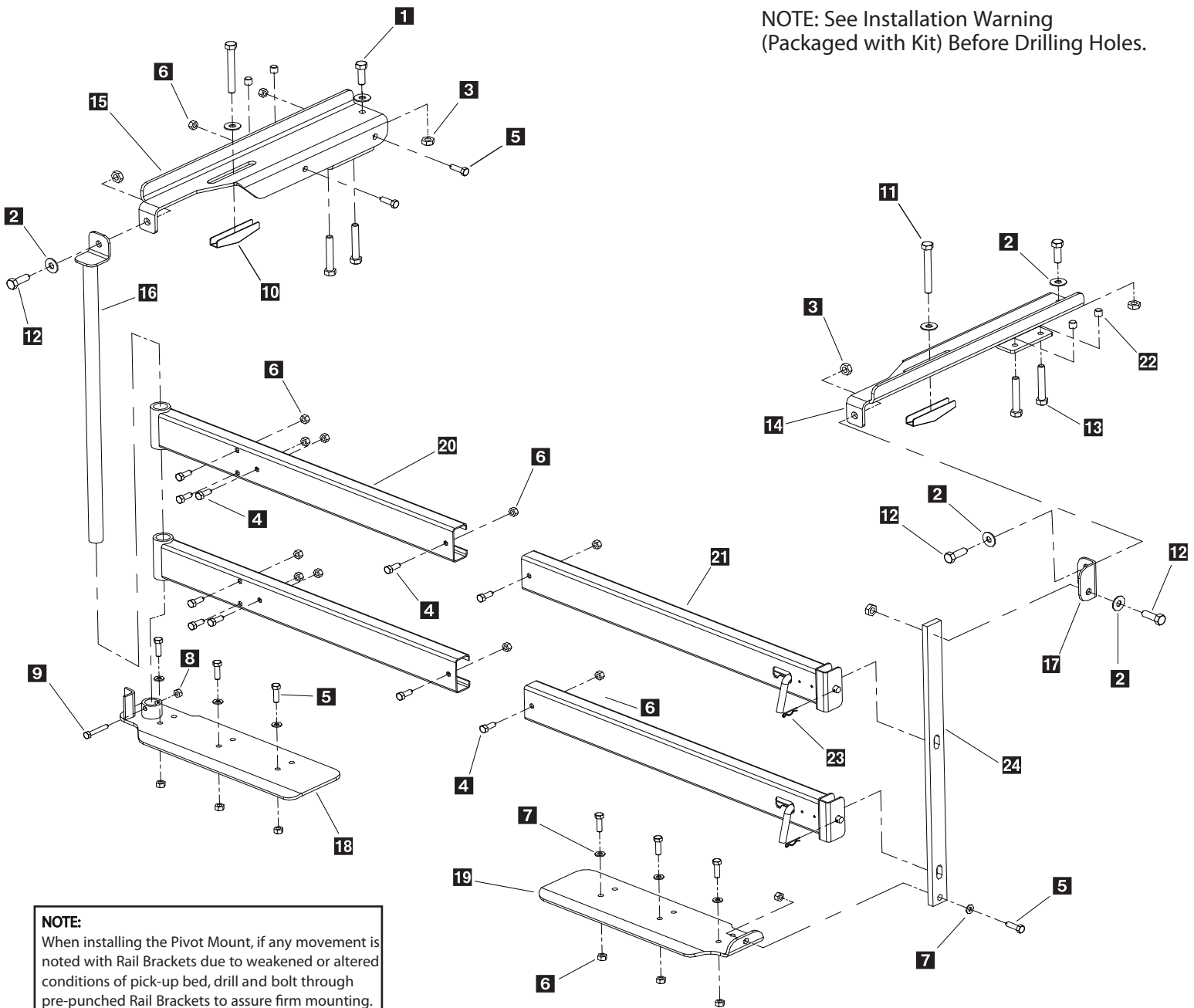

NOTE:
When installing the Pivot Mount, if any movement is noted with Rail Brackets due to weakened or altered conditions of pick-up bed, drill and bolt through pre-punched Rail Brackets to assure firm mounting.

Key	Part No.	Description	Qty.	Key	Part No.	Description	Qty.
1	D 4116	1/2-13 x 1-1/2" Hex Bolt	2	13	D 6144	1/2-13 x 3" Hex Bolt Full Thread	4
2	D 4119	1/2" Flat Washer	7	14	D 6200	Bed Rail Bracket Right	1
3	D 4120	1/2" Lock Nut	5	15	D 6201	Bed Rail Bracket Left	1
4	D 4121	3/8-16 x 1" Hex Bolt	16	16	D 6202	Pivot Tube Assembly	1
5	D 4122	3/8-16 x 1-1/2" Hex Bolt	13	17	D 6203	Angle Top	1
6	D 4124	3/8 Lock Nut	29	18	D 6204	Pivot Bumper Bracket	1
7	D 4125	3/8 Flat Washer	9	19	D 6205	Latch Bumper Bracket	1
8	D 6138	5/16 Lock Nut	1	20	D 6206	Pivot Channel Assembly	2
9	D 6139	5/16-18 x 2" Hex Bolt	1	21	D 6207	Latch Channel Assembly	2
10	D 6141	1/2" Toggle	2	22	D 6208	Rubber Tip Protector	4
11	D 6142	1/2-13 x 4" Hex Bolt Full Thread	2	23	D 6222	1/8" x 2-1/16" Hair Pin Clip	2
12	D 6143	1/2-13 x 1-1/4" Hex Bolt	3	24	D 6223	Latch Bar	1

Pivot Mount Installation Instructions



Model #PMT-175

Step 1: Insert upper & lower pivot rails into main frame of spreader. Line up the pre-punched holes on the pivot rail with the main frame, then bolt together. Holes are pre-determined and can be relocated if spreader is not centered on vehicle.

Step 2: Locate top bed rail mounting brackets and set on top of pickup bed rails; Center by moving out towards the bumper. maintain a minimum of 2" clearance between tailgate and spreader.

Step 3: Locate left and right bumper brackets. The left side or the pivot side will have a two piece system that will act as the hinge for the spreader. (See fig. D) The right side will have a two-piece system that will be the latching side. (See fig. H). Attach pivot tube and latch bar to the bumper plates using the posts as centering guides. Line up with the bed rail brackets. Be sure that the tailgate will open before locating any of these brackets permanently. Make sure bumper brackets are parallel to the lower main frame so that everything will be straight. After aligning all pieces, mark & drill holes using the bumper plates as a guide. (As seen in Fig. A) Once holes have been drilled bolt securely to bumper. Note: Use a minimum of 3 holes.

Step 3-A: If installing on a newer Chevrolet vehicle with a bumper that has raised ends, you will need to install one inch spacers supplied with kit PMT-175-C (see pg. 7-38) for illustration.

Step 4: Locate toggle bolt assembly and install on left and right upper bed rail brackets as seen in (Fig. B). Position toggle bolt (Fig. C) to keep in position while tightening. Pull up on the bracket to keep a slight amount of pressure on the toggle bolt. ***NOTE***: When tightening toggle bolt assembly, do not exceed 30 foot pounds of torque, or you may damage toggle assembly. Take the two 3" full threaded bolts and screw into bottom of bed rail brackets. Use rubber tip protectors on bolt end as seen in (Fig E). Torque bolts down using a **HAND RATCHET ONLY**- you may also want to use a small amount of blue removable thread locker. Do this only as a final assembly once you have proper tailgate clearance established.

Step 4A: Please make sure toggle is positioned so front to back in line with vehicle, this is very important. If the toggle makes contact with the rear inside surface of the pickup box, you may cause an internal dent that will show on the exterior of the box. Also you can damage the paint which can be very costly to repair, not to mention a huge inconvenience for everyone. Please take your time during this step and be sure it is done correctly.

Step 5: Now that the lower bumper brackets and upper bed rail brackets are mounted, you will now need to check both the pivot tube assembly and latch bar to see if these need to be cut down. Due to the variety of truck bumpers, bed rail heights, etc, we made these two parts intentionally too long. On the pivot side you will need to align the top of the pivot tube hole to the left side bed rail bracket hole. Trim off the amount needed with a cut off saw.

Step 6: Put this piece aside for now. Now that you have the pivot side assembly cut to length, mount spreader main frame assembly to truck. With an assistant, place pivot side of spreader on truck. Take pivot tube assembly and insert through pivot rails to the bumper plate locator tube. Bolt the upper pivot tube assembly to the bed rail bracket.

Make sure bed rail bracket is secure. Swing spreader until both support pads on lower main frame rail are completely on the bumper. Drill a 5/16" hole, (as seen in Fig D) and bolt lower portion of pivot tube assembly. This will now complete pivot side installation.

Step 7: The latching side will be done the same way, except that you will need to mount the locator bracket to the right side bed rail bracket (see Fig F, G, H). Once you have completed, trim flush with the top of the locator bracket. After cutting bar to proper length, drill a 1/2" hole in mounting bar. Bolt the upper portion and the lower portion of the latching bar.

Step 8: Locate latching rails and insert into spreader main frame, position the latch rails so they are latched to the latching bar. Center latching bar in the pocket of the end of the latch rail. (see Fig. F) This will insure proper latching when closing spreader.

Step 9: Using an assistant or a large vice grip to insure rails do not move, drill three 3/8" holes using the pre-punched holes as a guide. Repeat this process for the lower rail also. Bolt together. This completes the latch side of the pivot mount.

Step 10: Drill four more 3/8" holes as seen in (Fig I) to stiffen the whole frame/rail system. Bolt together. This will insure minimum frame deflection under extreme load conditions.

Step 11: Make sure spreader is level and clear from the tailgate when closed. You can make minor adjustments by loosening the bed rail brackets (one at a time) and trimming the unit out. Also at this time you may want to apply a small amount of removable thread locker to insure the bolts stay secure.

Step 12: Lube zerk fittings on pivot tubes.

Step 13: **IMPORTANT:**When installing the Pivot Mount, if any movement is noticed with the bed rail brackets due to weakness or altered conditions of pickup bed, drill and bolt thru the pre-punched holes located on the sides of the bed rail brackets and bolt securely.

Step 14: After first use, tighten all nuts and bolts on mount and spreader.

Pivot Mount Parts Breakdown

Model #PMT-175-C (For GM and Chevrolet 2007 Models and Newer 2500 HD and Larger)

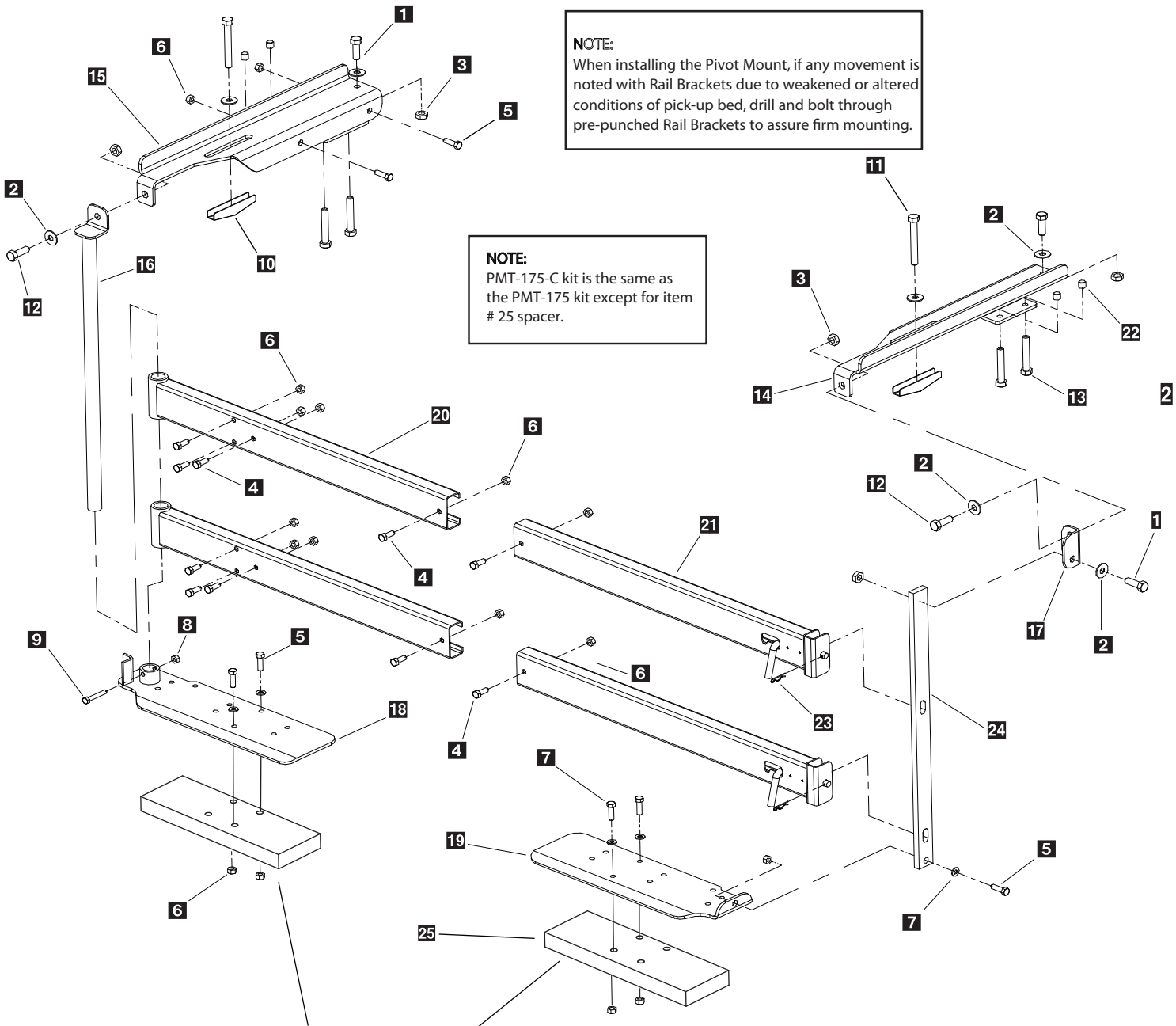

NOTE:
When installing the Pivot Mount, if any movement is noted with Rail Brackets due to weakened or altered conditions of pick-up bed, drill and bolt through pre-punched Rail Brackets to assure firm mounting.

NOTE:
PMT-175-C kit is the same as the PMT-175 kit except for item # 25 spacer.

BUMPER PLATE SPACER FOR BUMPER OBSTRUCTION ON CHEVROLET VEHICLES

Key	Part No.	Description	Qty.	Key	Part No.	Description	Qty.
1	D 4116	1/2-13 x 1-1/2" Hex Bolt	2	13	D 6144	1/2-13 x 3" Hex Bolt Full Thread	4
2	D 4119	1/2" Flat Washer	7	14	D 6200	Bed Rail Bracket Right	1
3	D 4120	1/2" Lock Nut	5	15	D 6201	Bed Rail Bracket Left	1
4	D 4121	3/8-16 x 1" Hex Bolt	16	16	D 6202	Pivot Tube Assembly	1
5	D 4122	3/8-16 x 1-1/2" Hex Bolt	13	17	D 6203	Angle Top	1
6	D 4124	3/8 Lock Nut	29	18	D 6204	Pivot Bumper Bracket	1
7	D 4125	3/8 Flat Washer	9	19	D 6205	Latch Bumper Bracket	1
8	D 6138	5/16 Lock Nut	1	20	D 6206	Pivot Channel Assembly	2
9	D 6139	5/16-18 x 2" Hex Bolt	1	21	D 6207	Latch Channel Assembly	2
10	D 6141	1/2" Toggle	2	22	D 6208	Rubber Tip Protector	4
11	D 6142	1/2-13 x 4" Hex Bolt Full Thread	2	23	D 6222	1/8" x 2-1/16" Hair Pin Clip	2
12	D 6143	1/2-13 x 1-1/4" Hex Bolt	3	24	D 6223	Latch Bar	1
				25	D 6739	Chevrolet Plastic Spacer Block	2

Pivot Mount Installation Diagrams

Model #PMT-175 / PMT-175-C

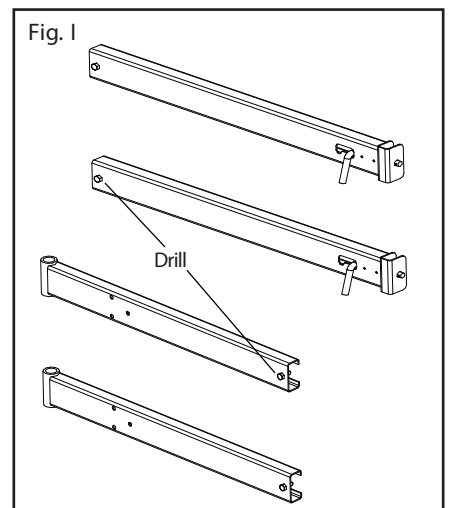
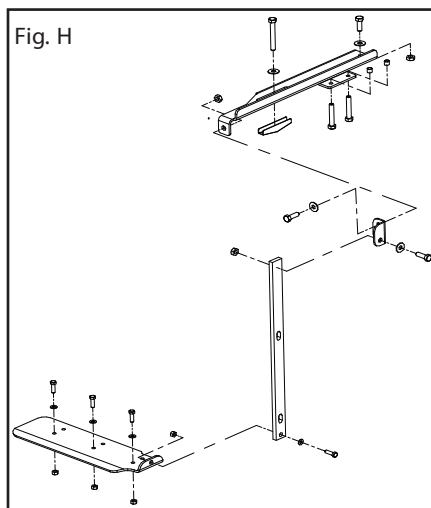
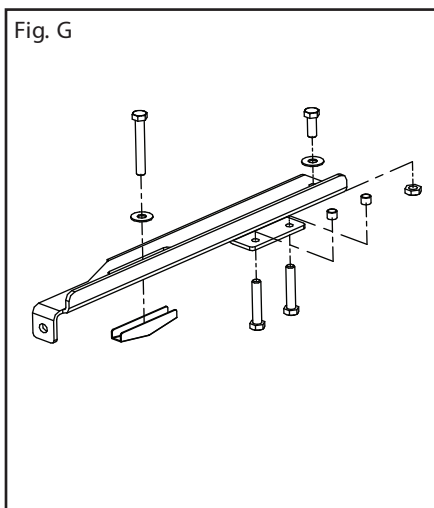
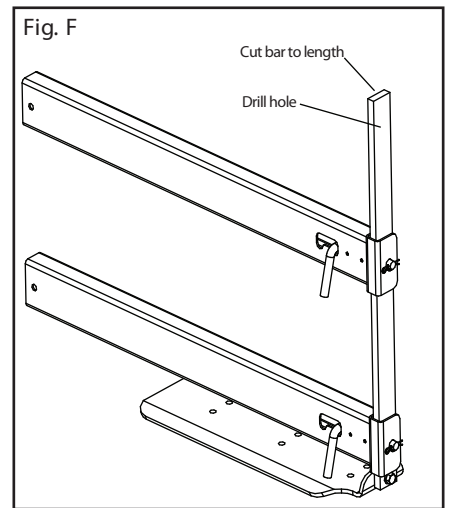
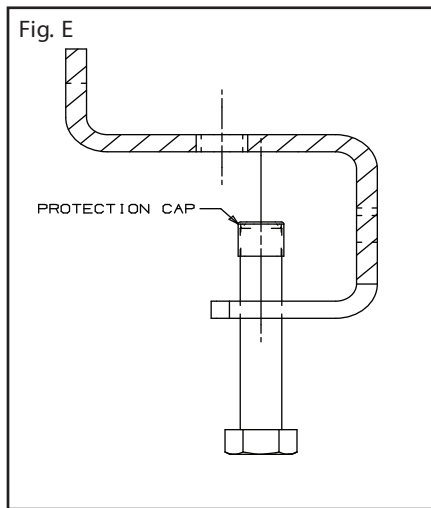
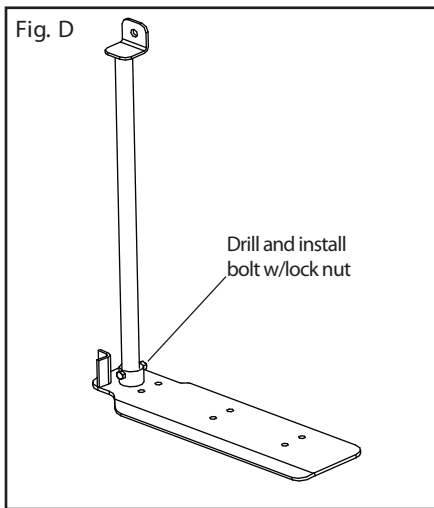
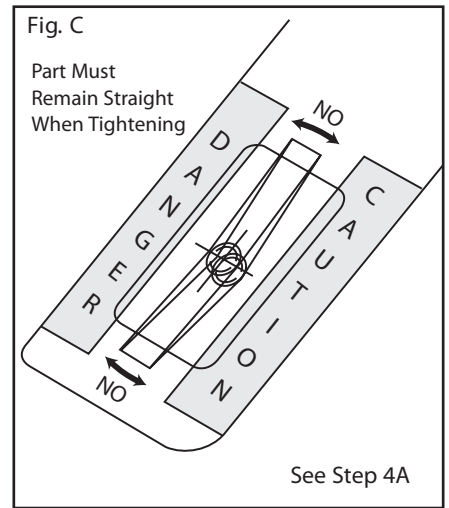
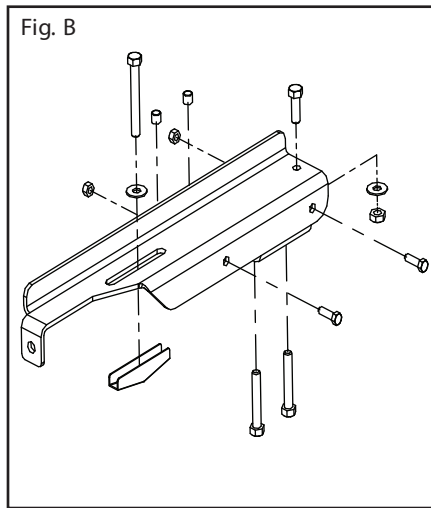
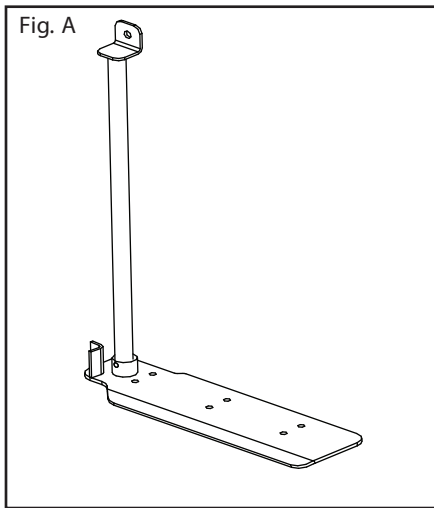

Three-Point Mount Parts Breakdown

Model #TPM-175

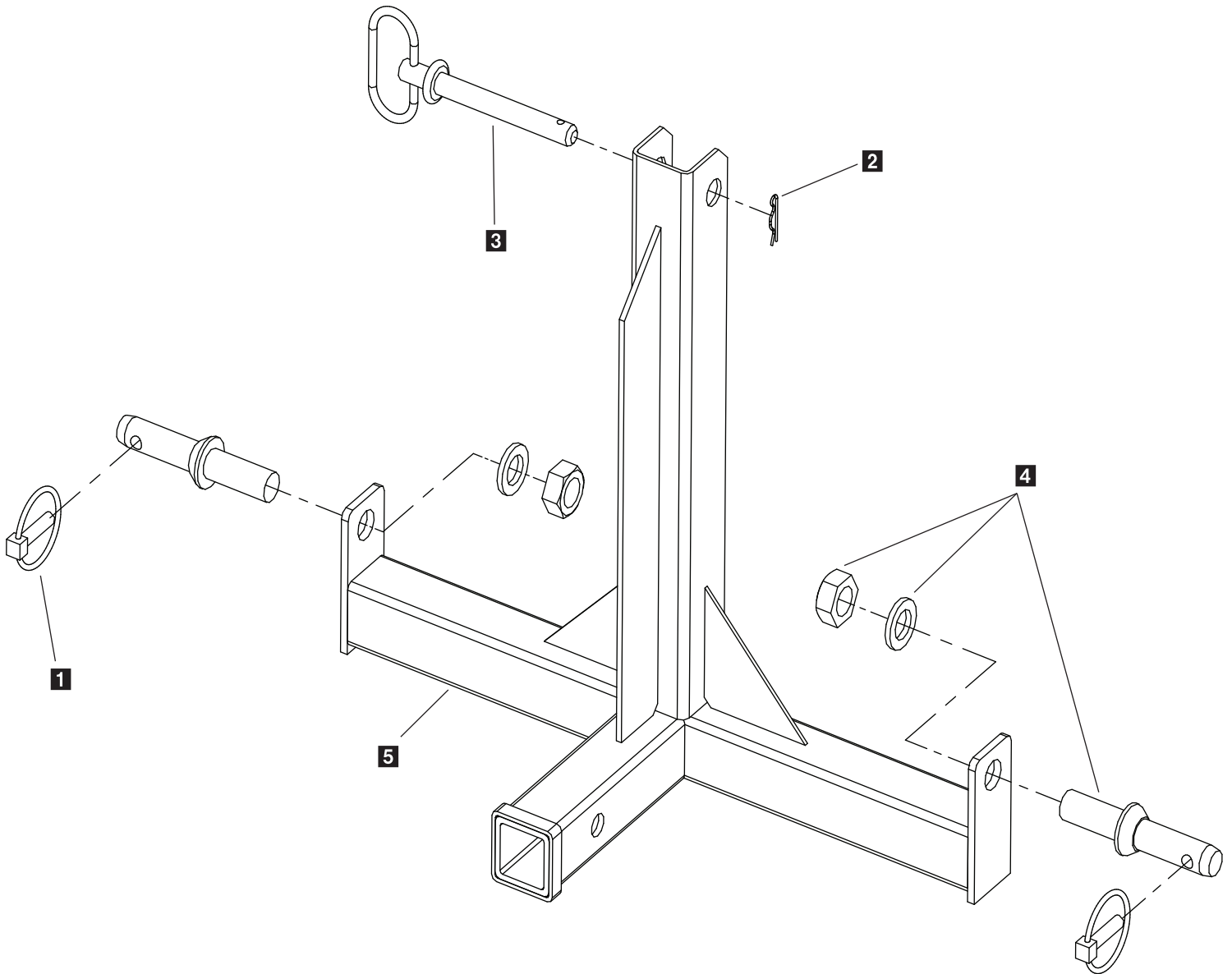

Key	Part No.	Description	Qty.
1	D 4133	5/16" Linch Pin	2
2	D 4135	2-5/16" Hairpin Clip	1
3	D 4136	5/8" x 5-1/2" Hitch Pin	1
4	D 4137	7/8" x 5-1/2" Lift Arm Pin	2
5	D 6147	Three Point Frame	1

CAUTION: MAXIMUM OF 240 LBS. GROSS WEIGHT CAN BE PUT ONTO MOUNT.

Trailer Mount Parts Breakdown

Model #TLR-175

MAXIMUM LOAD WEIGHT NOT TO EXCEED 240 LBS. GROSS

TRAILER MOUNT ASSEMBLY INSTRUCTIONS

Step 1: Insert axle through wheel and axle weldment.

Step 2: Put washer on, then install hair pin clip to secure axle. Repeat Steps 1 and 2 for other side.

Step 3: Bolt tube support on axle weldment.

Step 4: Insert trailer tongue per drawing and pin into position.

Step 5: Insert spreader mount into opposite side of trailer tongue and pin into position.

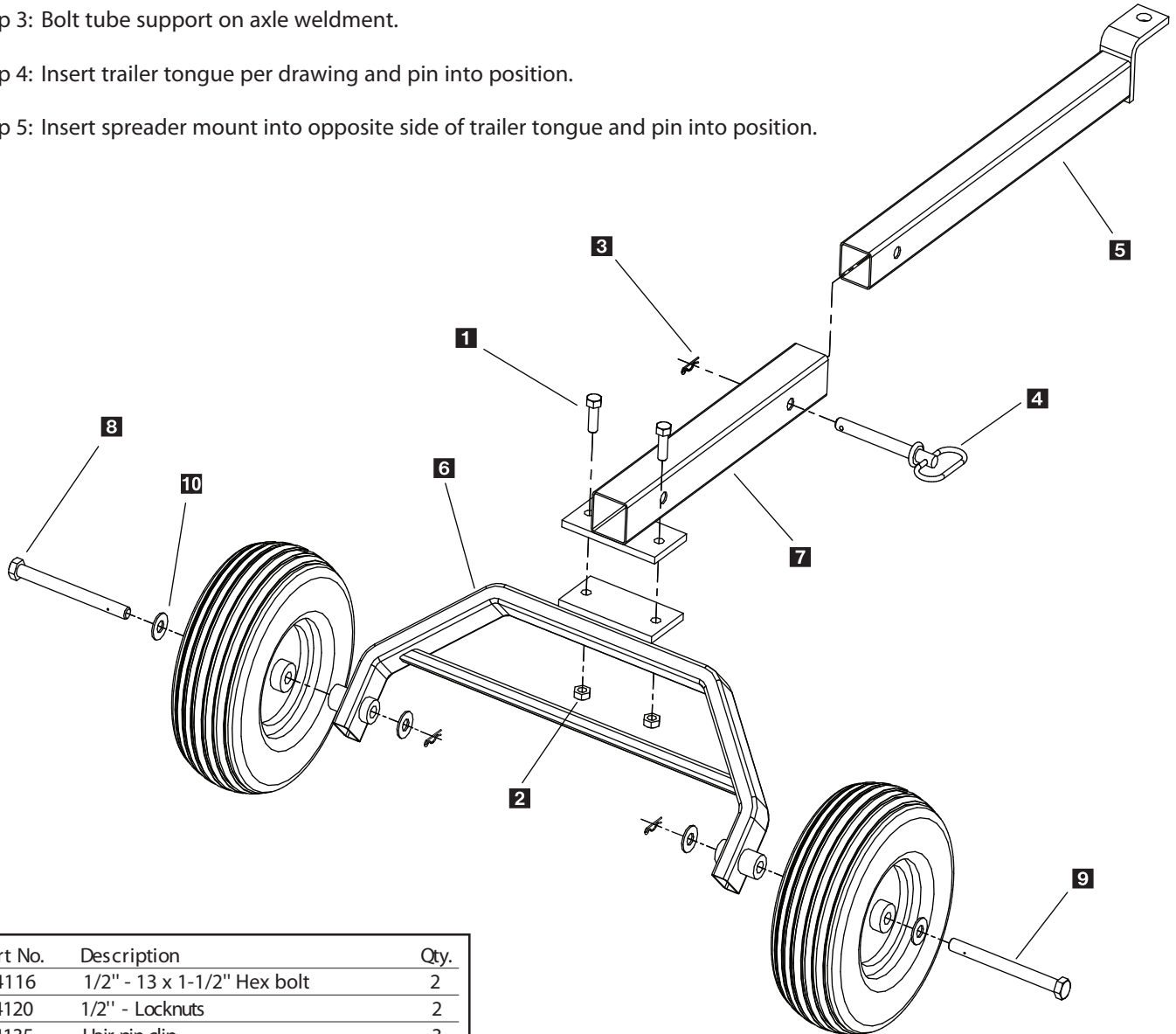

Key	Part No.	Description	Qty.
1	D 4116	1/2" - 13 x 1-1/2" Hex bolt	2
2	D 4120	1/2" - Locknuts	2
3	D 4135	Hair pin clip	3
4	D 4136	5/8" x 5 -1/2" Hitch pin	1
5	D 6438	Trailer tongue	1
6	D 6439	Trailer "A" frame	1
7	D 6440	Receiver tube mount	1
8	D 6441	Trailer tire	2
9	D 6442	5/8" - 13 x 7" Hex bolt special	2
10	D 6443	5/8" Flat washers	4

Drop Utility Mount Parts Breakdown

Model #DRM-175

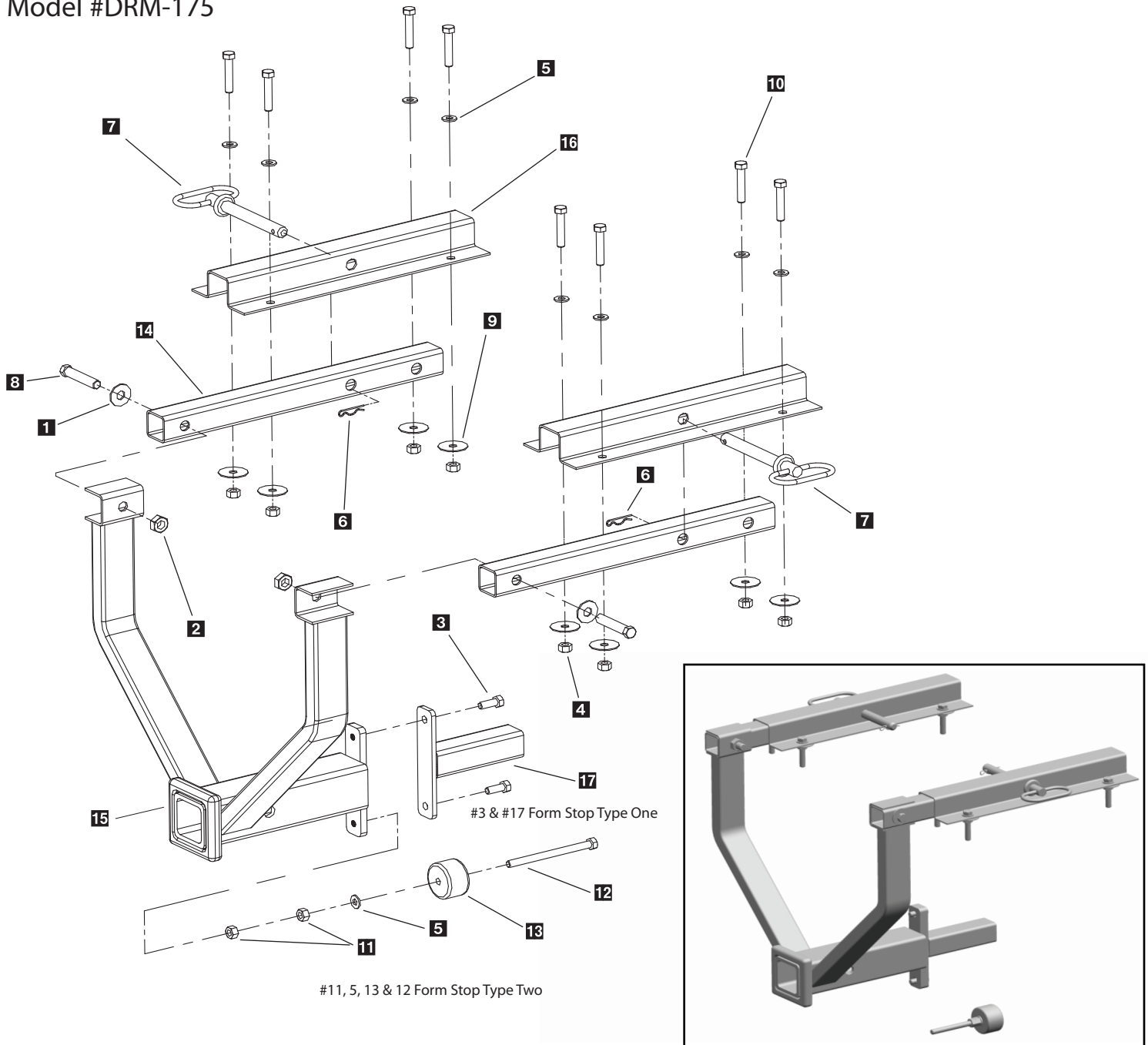

Maximum Load Weight Not To Exceed 240 lbs. Gross

Key	Part No.	Description	Qty.	Key	Part No.	Description	Qty.
1	D 4119	1/2" Flat Washer	2	10	D 6420	3/8" - 16 x 2 Truss Bolt Full Thread	8
2	D 4120	1/2"-Lock Nut	2	11	D 6421	3/8" - 16 Hex Nut	2
3	D 4121	3/8"-16x1 Hex Bolt	2	12	D 6422	3/8" - 16 x 5" Hex Bolt	1
4	D 4124	3/8"-Lock Nut	8	13	D 6423	2" Rubber Stopper	1
5	D 4125	3/8" Flat Washer	9	14	D 6432	Mounting Rail	2
6	D 4135	2 - 5/16" Hair Pin Clip	2	15	D 6434	Drop Mount Weldment	1
7	D 4136	5/8" x 5-1/2" Hitch Pin	2	16	D 6435	Mounting Rail Hat Section	2
8	D 6246	1/2" - 13 x 2-1/2" Hex Bolt	2	17	D 6436	Mule Adapter	1
9	D 4318	3/8" Fender Washer	8				

Drop Utility Mount Installation Instructions

Model # DRM-175

MULE 550

Step 1: Temporarily remove the tailgate. Remove the bed liner if equipped.

Step 2: Bolt support rails to spreader mount with 1/2" bolts. Install 1/2" hex bolt with washer through rail first then spreader mount. Install 1/2" locknut and tighten. Avoid over tightening to avoid potentially crushing tube.

Step 3: Place spreader mounting rails over spreader mount support rails and install pins. Locate the spreader bracket mounting rails on top of the bed by centering left to right and positioning the rear edge of the rails 5/8" beyond the rear of the bed. Transfer mounting holes to bed and drill 7/16" holes.

Important: Check for proper clearance underneath bed before drilling holes.

Step 4: Bolt rails under belt with truss head bolts, fender washers, SAE washers and nylock nuts. Install the spreader bracket before tightening hardware. The tailgate and bed liner may be reinstalled now.

Step 5: Install 550 anti dump bracket with (2) 3/8" bolts provided.

Step 6: Install gate control cable per attached instructions.

Step 7: Route Cables at your discretion and install switch.

MULE 2500

The installation of the spreader on the 2500 is the same as the 550 with the following exceptions.

Step 1: When positioning the mounting rails, the end of the rail should be 1/2" forward of the rear edge of the bed.

Step 2: The universal anti dump threads into the lower weld nut on the spreader bracket assembly. Adjust rubber bumper to be 1/2" to 3/4" behind the rear axle-receiver hitch assembly.

CLUB CAR CARRYALL

Step 1: Remove the bed tailgate and bottom angle trim. Also remove the two rear carriage bolts from the floor of the bed. Locate the two front outside mounting rails over the holes from the carriage bolts and remove.

Step 2: Place spreader mounting rails over spreader mount and install pins.

Step 3: Install truss head bolts, fender washers, SAE washers and nylock nuts in the carriage bolt holes. Transfer the remaining mounting rail holes and bolt rails into bed.

JOHN DEERE GATOR

Step 1: Remove the bed tailgate.

Step 2: Place spreader mounting rails over spreader mount and install pins.

Step 3: Locate the spreader bracket mounting rails on top of the bed by centering left to right, push main mount flush up against rear of bed to locate mounting rails. Transfer mounting holes to bed.

Step 4: Install truss head bolts, fender washers, SAE washers and nylock nuts in the 1/2" mounting holes.

Step 5: The universal anti dump threads into the lower weld nut on the spreader bracket assembly. The rubber bumper should be adjusted to rest against the frame of the vehicle. The trailer hitch bracket may need to be relocated depending on the configuration.

CAUTION: MAXIMUM WEIGHT NOT TO EXCEED 240 LBS.

Utility Mount Parts Breakdown

Model #UTM/FLM-175

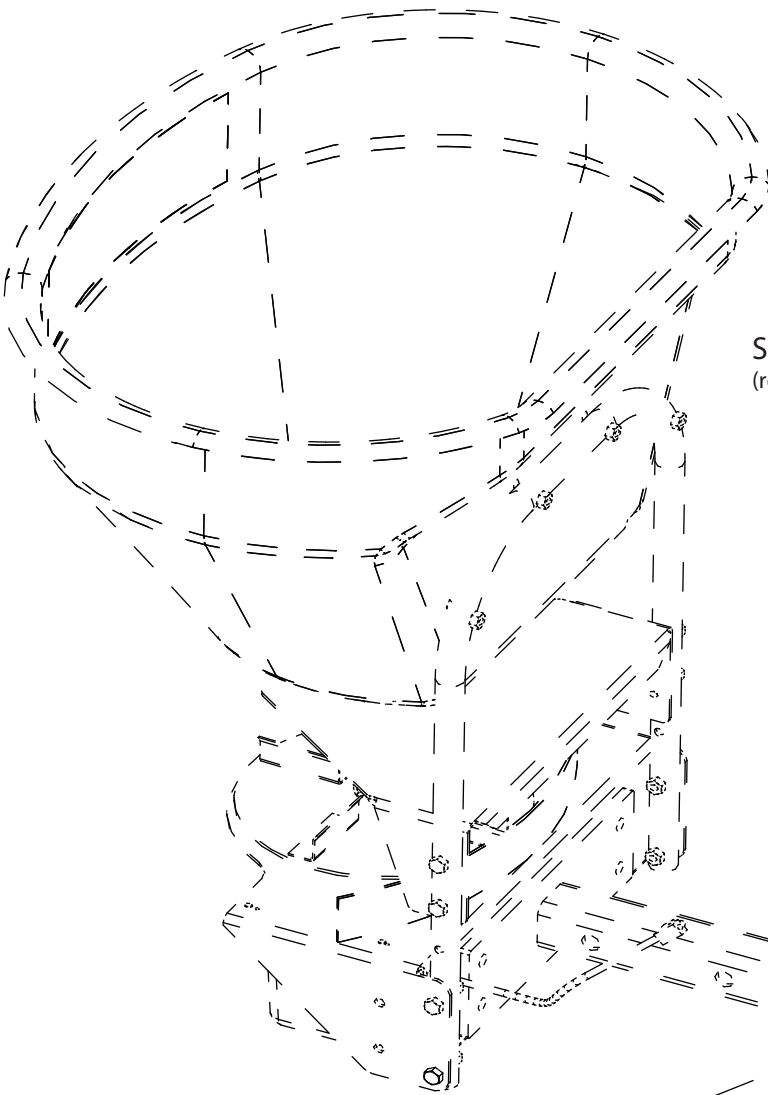

Spreader
(reference only)

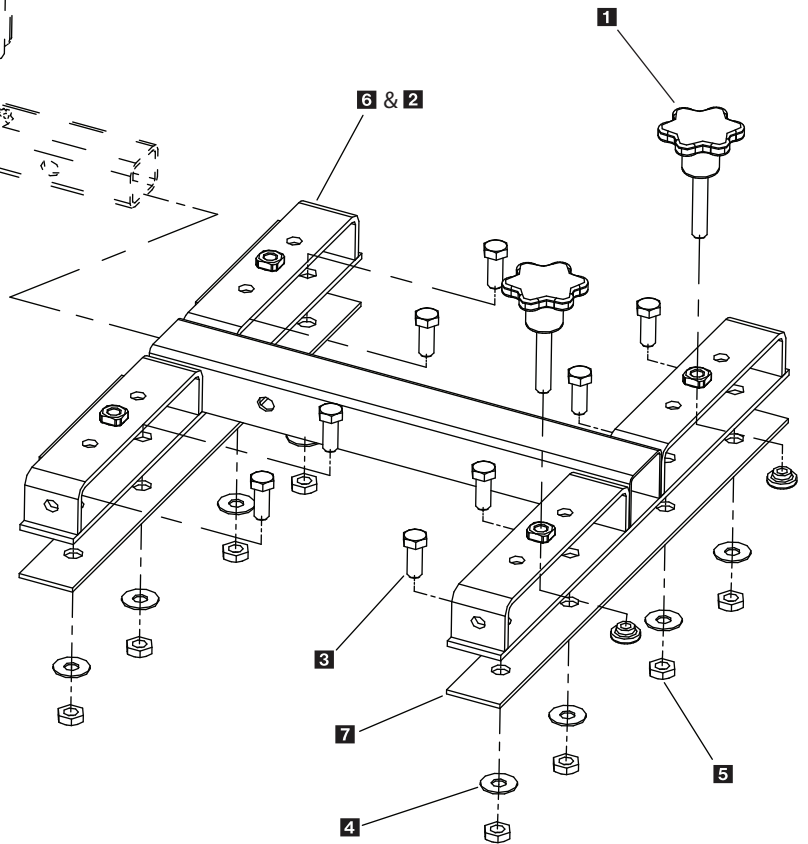

Maximum Load Weight
Not To Exceed 240 lbs. Gross

Key	Part No.	Description	Qty.
1	D 4315	Lock Knob Assembly (FLM-175 Only)	2
2	D 6426	Fork Lift Mount Frame (FLM)	1
3	D 4116	1/2"-13 x 1 1/2" Hex Bolt	8
4	D 4119	1/2" Flat Washer	8
5	D 4120	1/2" Lock Nut	8
6	D 6148	Utility Receiver (UTM)	1
7	D 6235	Underbody Support Plate	2

Pivot Pal Mount Parts Breakdown

Model #PPT-175

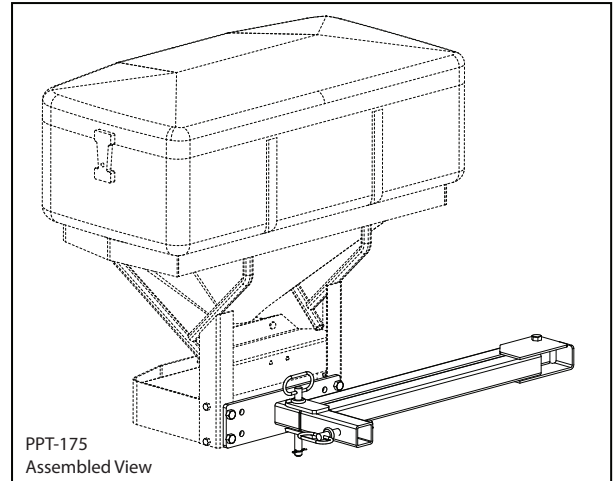
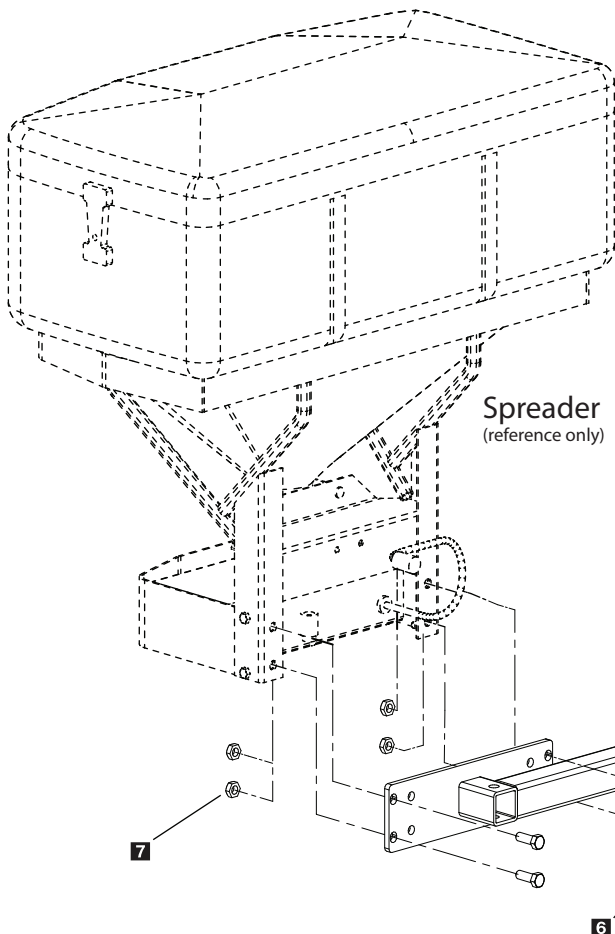

Step 1: Assemble spreader swing arm **2** to spreader hitch arm **1** with **8** and **4** & **5** nut and bolt. Do not over tighten since this may cause the arm to bind and will not swing open freely.

Step 2: Collapse assembly and install **3** hitch pin to keep assembly from opening.

Step 3: Remove existing 1/2" bolts from spreader drive assembly and mount spreader assembly to spreader (see illustration). Re-tighten hardware per illustration.

Step 4: With assistance, lift spreader into position and insert into vehicle receiver mount. Install **3** hitch pin with clip.

Step 5: Remove swing arm hitch pin and swing spreader out on drivers side, at this time use a spray lubricant such as automotive lithium type or a grease based product. This will help prevent unwanted corrosion in the pivot joint; this should be checked on a regular basis during the season.

Step 6: Close spreader and re-install hitch pin with clip.

Step 7: Plug spreader into spreader harness and test for power on.

Key	Part No.	Description	Qty.
1	D 6051	Hitch Arm	1
2	D 6052	Swing Arm	1
3	D 4136	Hitch Pin With Clip	2
4	D 6052	1/2" x 2-1/2" Shoulder Bolt	1
5	D 4124	3/8"-16 Nylon Hex Nut	1
6	D 4116	1/2"-13 x 1-1/2" Hex Bolt	4
7	D 4120	1/2"-13 Lock Nut	4
8	D 6049	1/2" x 1/6" Bronze Thrust Washer	2

Whenever service is necessary, your local SnowEx Dealer knows your Spreader best. Take your Spreader to your local dealer for any maintenance or service needs on your unit. If this is not possible, the Troubleshooting Guide below may assist you in identifying the problem.

Warning: First read all warning instructions and safety messages before servicing your spreader.

Preliminary Checks

- Be sure all electrical connections are tight and clean.
- Be sure nothing is jammed in the hopper.

PROBLEM	POSSIBLE CAUSE	SOLUTION
Motor doesn't run.	Loose electrical connections.	Check all connections.
	Blown Fuse.	Replace fuse.
	Motor Seized.	Replace motor.
Controller shut down.	Jammed auger.	Carefully clear jammed material.
	Poor electrical connections.	Clean or replace connectors. Use dielectric grease.
	Electrical short.	Check electrical connections. Check for bare wires.
	Controller failure.	Replace controller.
Material not flowing from hopper.	Empty hopper.	Fill hopper.
	Wet material.	Replace with dry material.
	Frozen or coarse material.	Replace material.
	Spinner not turning.	Check drive assembly.
	Auger loose on shaft.	Tighten locking bolt on the side of the auger. There is a flat machined on the driver shaft. Align the auger with this flat and tighten the bolt.
	Vibrator not working.	Replace vibrator
Audible alarm beeping and display shows OL or OH.	Jammed auger, overload shut down.	Turn off for three seconds, then restart. If shut down continues, turn off controller. Clear debris and lumps from auger areas.
Audible alarm beeping display shows E1.	Short in system.	Turn off. Do not use until problem is corrected.
Audible alarm beeping display shows EO.	Motor is not getting power.	Turn off. Check all connections.
Audible alarm beeping display shows LB.	Vehicle battery is extremely low, or a poor connection exists.	Turn off. Charge battery.

Troubleshooting

Model # SP-1875

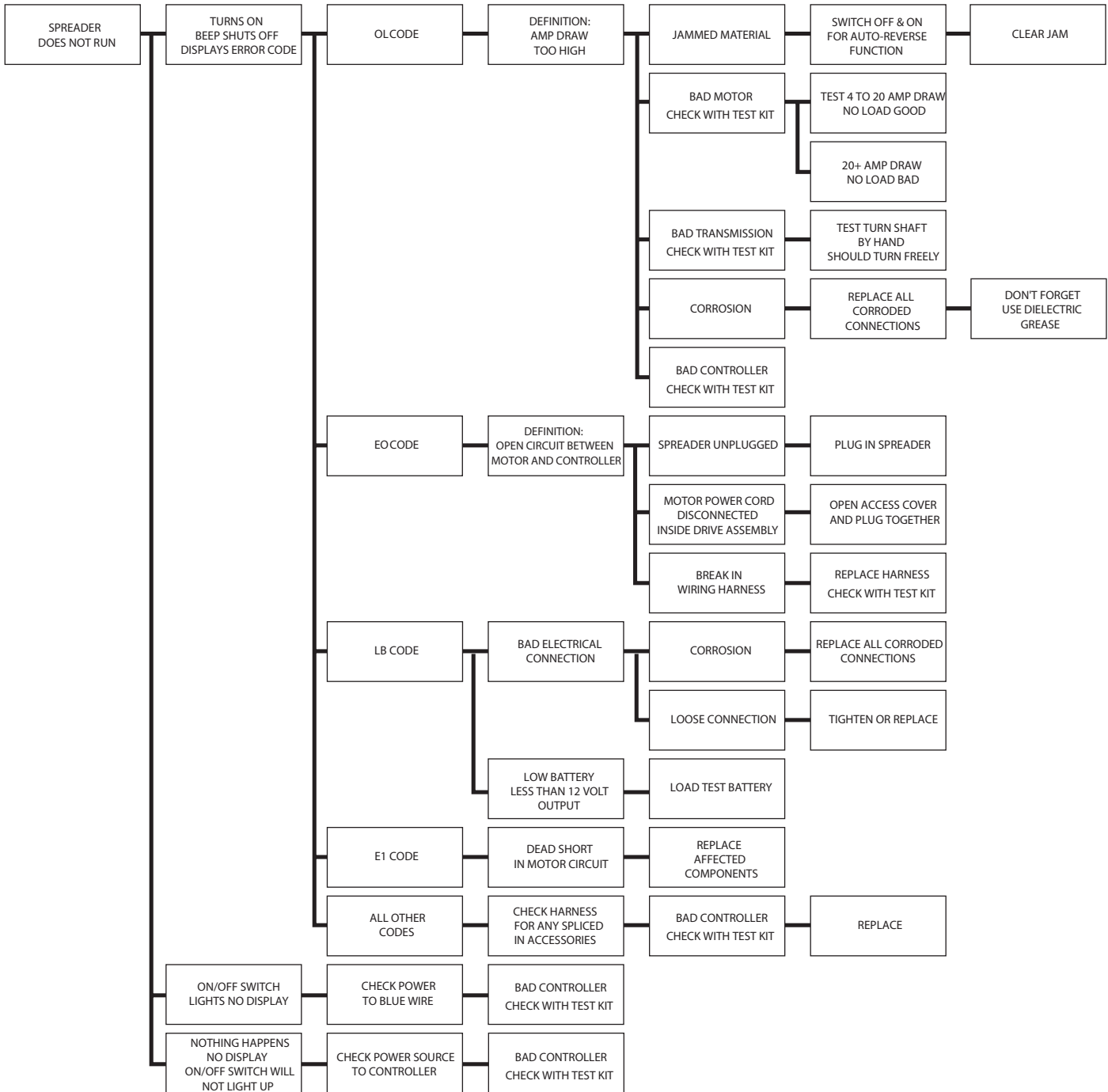

SNOWEX DIAGNOSTIC TEST KIT (STK-020) IS AVAILABLE TO ACCURATELY DIAGNOSE ANY ISSUES WITH SNOWEX SPREADERS. CALL YOUR DEALER FOR DETAILS.

Troubleshooting Material Flow

Model # SP-1875

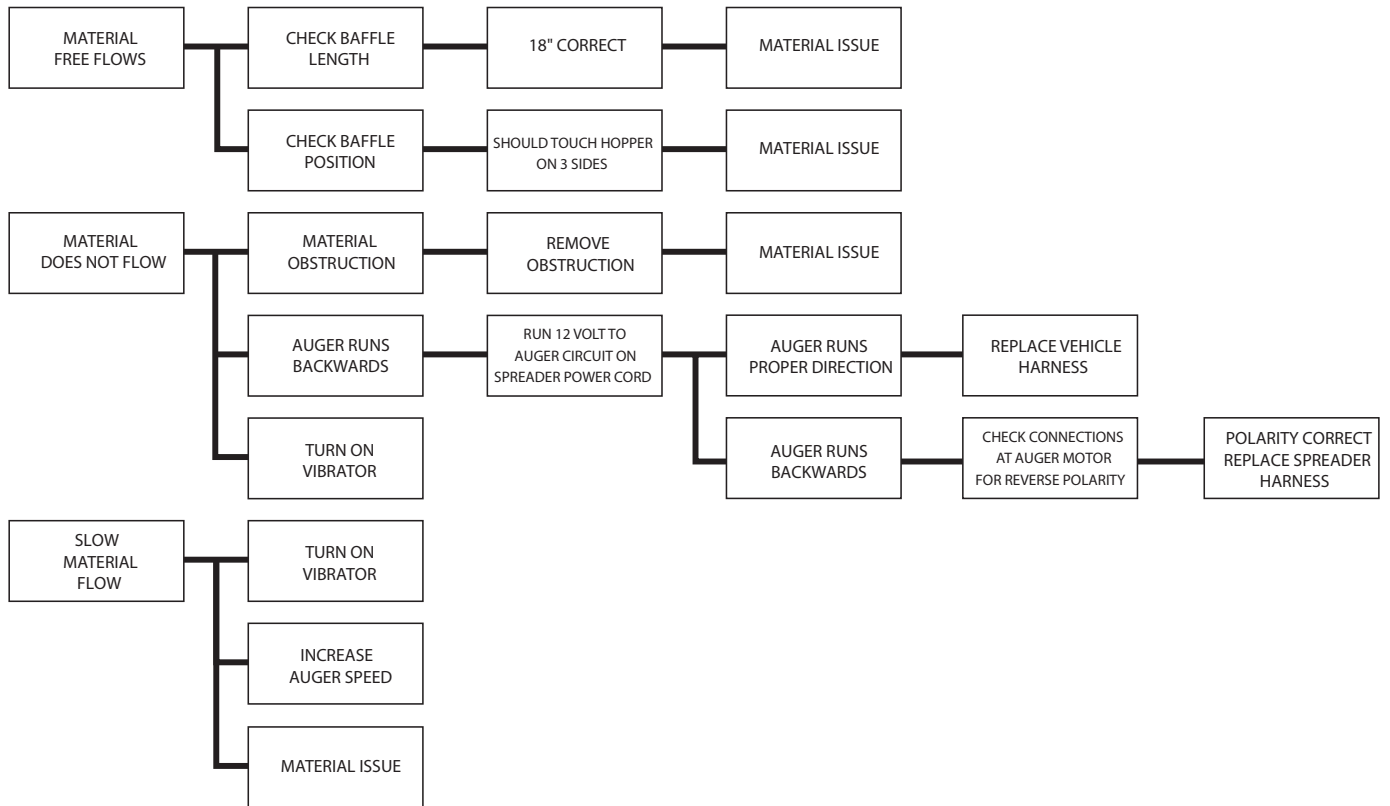

SNOWEX DIAGNOSTIC TEST KIT (STK-020) IS AVAILABLE TO ACCURATELY DIAGNOSE ANY ISSUES WITH SNOWEX SPREADERS. CALL YOUR DEALER FOR DETAILS.

Troubleshooting

Model # SP-575/SP-1075

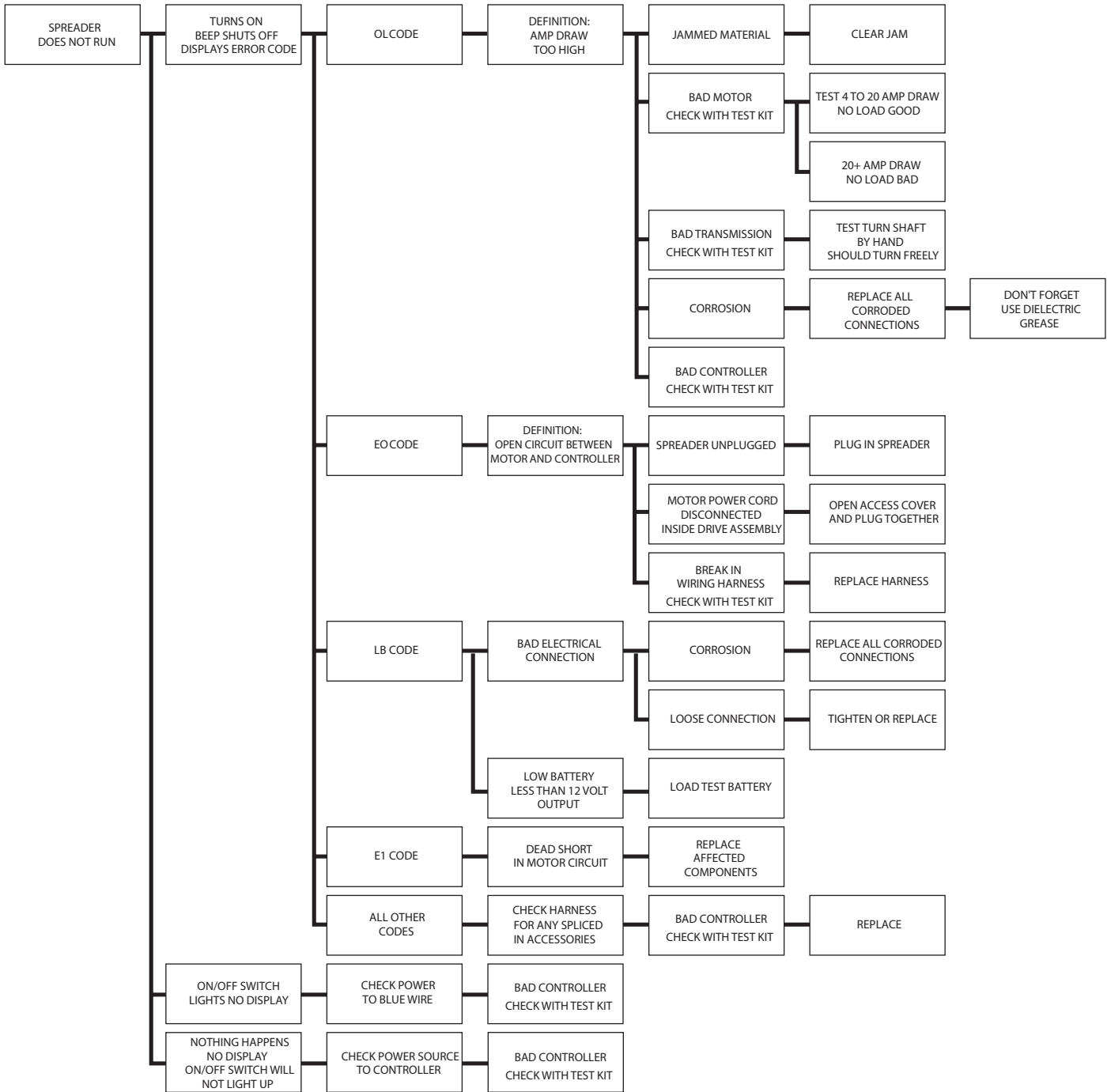

SNOWEX DIAGNOSTIC TEST KIT (STK-020) IS AVAILABLE TO ACCURATELY DIAGNOSE ANY ISSUES WITH SNOWEX SPREADERS. CALL YOUR DEALER FOR DETAILS.

Troubleshooting

Model # SP-575/SP-1075

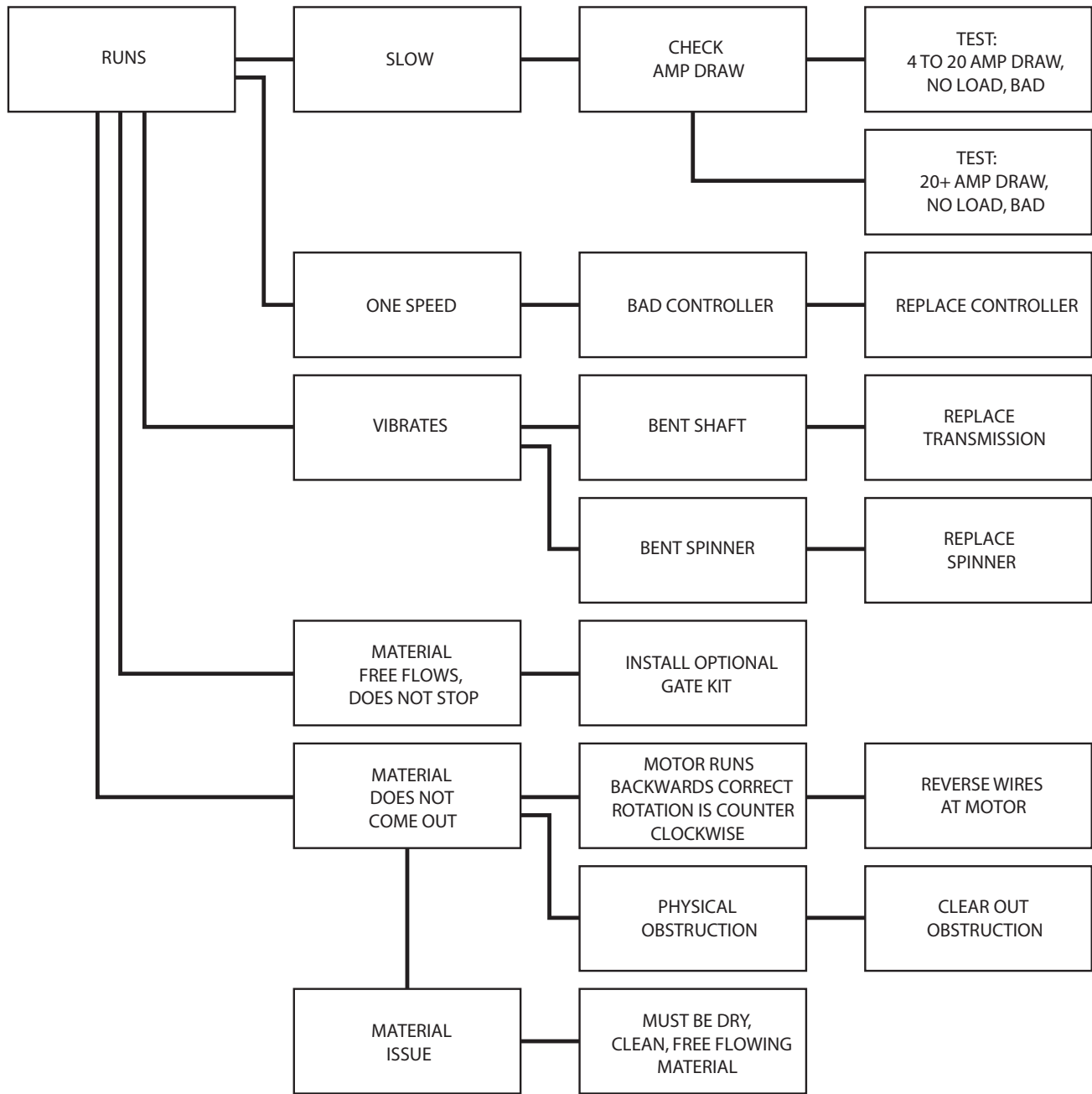

NOTE: Optional Vibrator Kit Available, To Increase Material Flow

SNOWEX DIAGNOSTIC TEST KIT (STK-020) IS AVAILABLE TO ACCURATELY DIAGNOSE ANY ISSUES WITH SNOWEX SPREADERS. CALL YOUR DEALER FOR DETAILS.

Troubleshooting

Model # SP-325

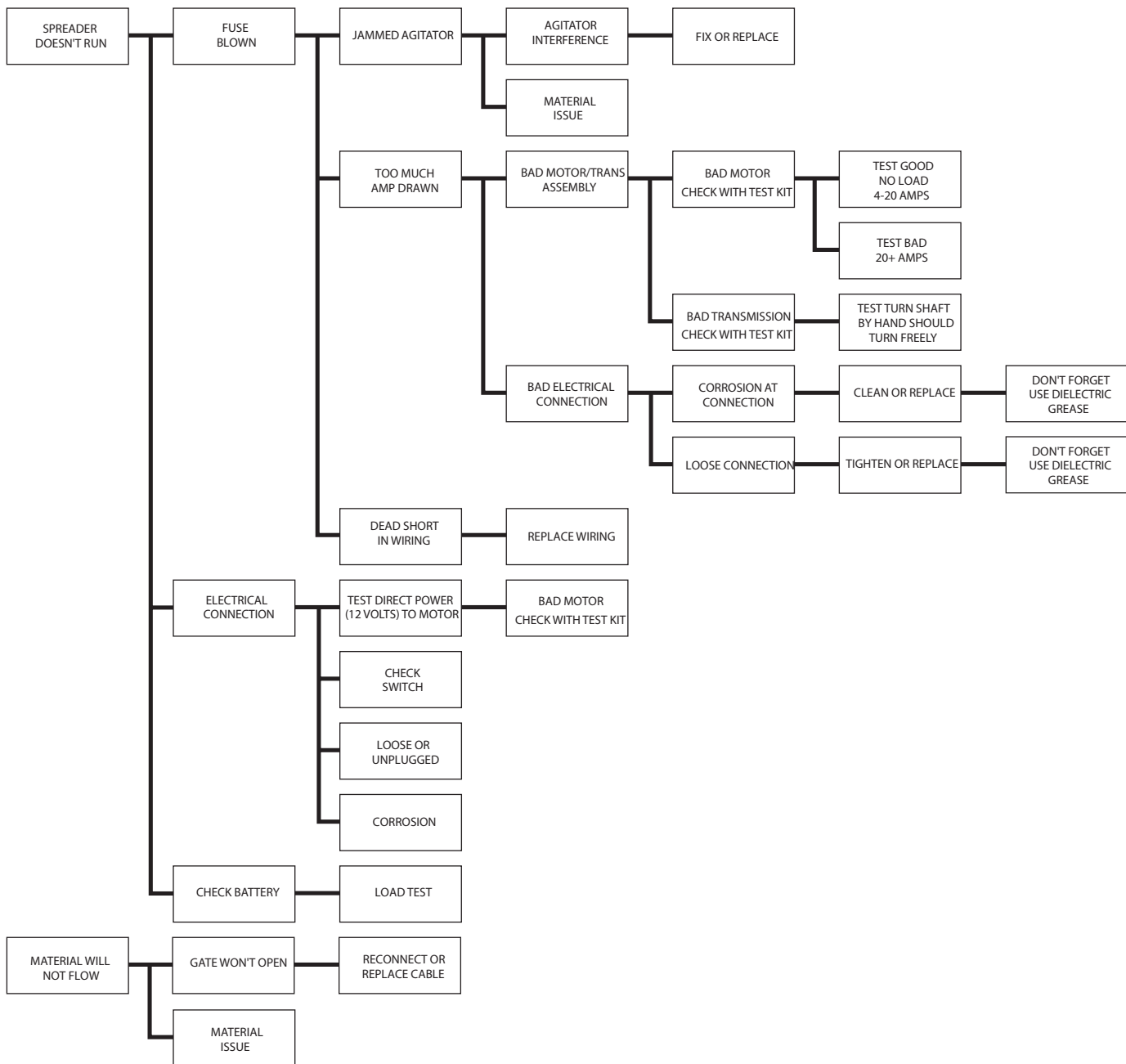

SNOWEX DIAGNOSTIC TEST KIT (STK-020) IS AVAILABLE TO ACCURATELY DIAGNOSE ANY ISSUES WITH SNOWEX SPREADERS. CALL YOUR DEALER FOR DETAILS.

- **WARNING** – When servicing is necessary, perform it in a protected area. Do not use power tools in rain or snow because of danger of electrical shock or injury. Keep area well lighted. Use proper tools. Keep the area of service clean to help avoid accidents.
- **WARNING** – Disconnect electricity to spreader before servicing.
- **CAUTION** – The controller is a solid state electronic unit and is not serviceable. Any attempt to service will void warranty.
- **CAUTION** – There are no serviceable parts in the motor/transmission assembly. Any attempt to service will void warranty.
- **CAUTION** – When replacing parts, use only original manufacturer's parts. Failure to do so will void warranty.
- Use dielectric grease on all electrical connections to prevent corrosion at the beginning and end of the season and each time power plugs are disconnected.
- Wash unit after each use to prevent material build-up and corrosion.
- **CAUTION** – When pressure washing motor enclosure area, stay at least 36" away from motor enclosures.
- Paint or oil all bare metal surfaces at the end of the season.
- Apply small amount of light oil to latches as needed.
- If motor cover is removed for any reason, use silicone sealant to ensure weather proofing of enclosure.
- Grease bearings after every 20 hour's use (SP-1875 only).
- After first use, tighten all nuts and bolts on spreader and mount.
- Apply a small amount of oil on gate cable to prevent corrosion and maximize the cable life (SP-375 & GAK-020).
- Keep pivot assembly well greased to prevent corrosion (PMT-175).
- **CAUTION** – Spinner motor is not designed for continuous duty. Allow motor to cool between long cycle times.

Limited Warranty

Snowex products are warranted for a period of two years from the date of purchase against defects in material or workmanship under normal use and service, subject to limitations detailed below. Warranty period of two years begins on the date of purchase by the original retail user.

The WARRANTY REGISTRATION CARD must be returned to the manufacturer for this warranty to become effective. This warranty applies to the original retail purchaser only. This warranty does not cover damages caused by improper installation, misuse, lack of proper maintenance, alterations or repairs made by anyone other than authorized Snowex dealers or Snowex personnel. Due to the corrosive properties of the materials dispensed by spreaders, Trynex does not warrant against damage caused by corrosion. Warranty claims by the user must be made to the dealer from where the product was purchased, unless otherwise authorized by Snowex. Snowex reserves the right to determine if any part is defective and to repair or replace such parts as it elects. This warranty does not cover shipping costs of defective parts to or from the dealer.

LIMITATION OF LIABILITY

Neither Snowex, nor any company affiliated with it, makes any warranties, representations for promise as to the performance or quality other than what is herein contained. The liability of Snowex to the purchaser for damages arising out of the manufacture, sale, delivery, use or resale of this spreader shall be limited to and shall not exceed the costs of repair or replacement of defective parts. Snowex shall not be liable for loss of use, inconvenience or any other incidental, indirect or consequential damages, so the above limitations on incidental or consequential damages may not apply to you.

NO DEALER HAS AUTHORITY TO MAKE ANY REPRESENTATION OR PROMISE ON BEHALF OF SNOWEX, OR TO ALTER OR MODIFY THE TERMS OR LIMITATIONS OF THIS WARRANTY IN ANY WAY.



Warranty Registration and Customer Survey

To initiate the warranty on your new SnowEx spreader and assure prompt warranty service, please complete the following warranty registration and customer survey, sign and mail it back to the factory within 30 days of purchase.

1) Date of Purchase: _____

2) Name: _____

Address: _____

Phone: _____

3) SnowEx Model Purchased: _____ Serial Number: _____

4) Is this your first Trynex Spreader? Yes No

5) What type of vehicle are you using with your Spreader?

Make _____ Model _____ Year _____

6) What type of material are you using in your spreader? _____

7) SnowEx Dealer Name: _____

SnowEx Dealer Address: _____

SnowEx Dealer Phone: _____

8) Does your Trynex Dealer stock Trynex replacement Parts? Yes No I don't know

9) Do you feel your Trynex Dealer sold you the correct product for your needs/application? Yes No

10) How would you rate your overall satisfaction with your SnowEx Dealer?	<input type="checkbox"/>	<input type="checkbox"/>	<input type="checkbox"/>	<input type="checkbox"/>	<input type="checkbox"/>	<input type="checkbox"/>
	Very Satisfied	Satisfied	Somewhat Satisfied	Somewhat Dissatisfied	Dissatisfied	Very Dissatisfied

11) How would you rate your overall satisfaction with your SnowEx Product?	<input type="checkbox"/>	<input type="checkbox"/>	<input type="checkbox"/>	<input type="checkbox"/>	<input type="checkbox"/>	<input type="checkbox"/>
	Very Satisfied	Satisfied	Somewhat Satisfied	Somewhat Dissatisfied	Dissatisfied	Very Dissatisfied

12) Would you purchase another Trynex Product? Yes No

13) If you would like to receive **E-Mail ALERTS** for new products, bulletins or special promotions please supply address: _____

14) Please use the space below to convey your comments and/or suggestions.

NOTE: I have read the owner's manual and all safety precautions and I understand that this equipment could be dangerous if not operated with care and under the proper conditions.

15) Owner's signature: **X** _____

PLEASE FOLD AND SEAL WITH TRANSPARENT TAPE BEFORE MAILING.